

Lasting Connections

WU 330

ISTRUZIONI PER L'USO
INSTRUCTION MANUAL
BETRIEBSANWEISUNG
MANUEL D'INSTRUCTIONS
INSTRUCCIONES DE USO
MANUAL DE INSTRUÇÕES

GEBRUIKSAANWIJZING
BRUKSANVISNING
BRUGERVEJLEDNING
BRUKSANVISNING
KÄYTTÖOHJEET
ΟΔΗΓΙΕΣ ΧΡΗΣΗΣ





Cod. 91.08.337
Data 21/06/2019
Rev.

ITALIANO	3
ENGLISH.....	9
DEUTSCH.....	15
FRANÇAIS.....	21
ESPAÑOL	27
PORTUGUÊS	33
NEDERLANDS.....	39
SVENSKA.....	45
DANSK.....	51
NORSK.....	57
SUOMI	63
ΕΛΛΗΝΙΚΑ.....	69
7 Targa dati, Rating plate, Leistungsschilder, Plaque signalétique, Placa de características, Placa de dados, Technische gegevens, Märkplåt, Dataskilt, Identifikasjonsplate, Arvokilpi, πινακίδα χαρακτηριστικων	75
8 Significato targa dati del WU, Meaning of WU data plate, Bedeutung der Angaben auf dem Leistungsschild des WU, Signification de la plaque signalétique du WU, Significado de la etiqueta de los datos del WU, Significado da placa de dados do WU, Betekenis van de WU gegevens kaart, Innebörden av uppgifterna på WU-enhetens märkplåt, Betydning af oplysningerne på WU-enhedens dataskilt, Beskrivelse av WU informasjonsskilt, WU kilven sisältö, Σημασία πινακίδας χαρ ακτηριότικων της WU	76
9 Schema, Diagram, Schaltplan, Schéma, Esquema, Diagrama, Schema, kopplingschema, Oversigt, Skjema, Kytentäkaavio, Διαγραμμα	77
10 Connettori, Connectors, Verbinder, Connecteurs, Conectores, Conectores, Verbindingen, Kontaktdon, Konnektorer, Skjøtemunnstykker, Liittimet, Συνδετηρες	78
11 Lista ricambi, Spare parts list, Ersatzteilverzeichnis, Liste de pièces détachées, Lista de repuestos, Lista de peças de reposição, Lijst van reserve onderdelen, Reservdelslista, Reservedelsliste, Liste over reservedeler, Varaosaluettelo, καταλογος ανταλλακτικων	80

DICHIARAZIONE DI CONFORMITA' CE

La ditta

SELCO s.r.l. - Via Palladio, 19 - 35019 ONARA DI TOMBOLO (Padova) - ITALY

Tel. +39 049 9413111 - Fax +39 049 9413311 - E-mail: selco@selcoweld.com - www.selcoweld.com

dichiara che l'apparecchio tipo

WU 330

è conforme alle direttive EU:

2014/35/EU

LOW VOLTAGE DIRECTIVE

2014/30/EU

EMC DIRECTIVE

2011/65/EU

RoHS DIRECTIVE

e che sono state applicate le norme:

EN 60974-2:2014

EN 60974-10:2015 Class A

Ogni intervento o modifica non autorizzati dalla **SELCO s.r.l.** faranno decadere la validità di questa dichiarazione.

Onara di Tombolo (PADOVA)

Selco s.r.l.



Lino Frasson
Chief Executive

INDICE

1 AVVERTENZE	5
1.1 Ambiente di utilizzo.....	5
1.2 Protezione personale e di terzi.....	5
1.3 Protezione da shock elettrico.....	5
1.4 Campi elettromagnetici e interferenze	5
1.5 Grado di protezione IP	6
1.6 Liquido di raffreddamento	6
1.6.1 Protezione personale	6
1.6.2 Smaltimento	6
2 INSTALLAZIONE	6
2.1 Modalità di sollevamento, trasporto e scarico.....	6
2.2 Posizionamento dell'impianto	6
2.3 Allacciamento	6
2.4 Messa in servizio.....	7
3 PRESENTAZIONE DELL'IMPIANTO	7
3.1 Pannello frontale	7
4 MANUTENZIONE	7
5 DIAGNOSTICA E SOLUZIONI.....	8
6 CARATTERISTICHE TECNICHE.....	8

SIMBOLOGIA



Pericoli imminenti che causano gravi lesioni e comportamenti rischiosi che potrebbero causare gravi lesioni



Comportamenti che potrebbero causare lesioni non gravi o danni alle cose



Le note precedute da questo simbolo sono di carattere tecnico e facilitano le operazioni

1 AVVERTENZE



Prima di iniziare qualsiasi operazione siate sicuri di aver ben letto e compreso questo manuale.

Non apportate modifiche e non eseguite manutenzioni non descritte.

Il produttore non si fa carico di danni a persone o cose, occorsi per incuria nella lettura o nella messa in pratica di quanto scritto in questo manuale.



Per ogni dubbio o problema circa l'utilizzo dell'impianto, anche se qui non descritto, consultare personale qualificato.



1.1 Ambiente di utilizzo

- Ogni impianto deve essere utilizzato esclusivamente per le operazioni per cui è stato progettato, nei modi e nei campi previsti in targa dati e/o in questo manuale, secondo le direttive nazionali e internazionali relative alla sicurezza. Un utilizzo diverso da quello espressamente dichiarato dal costruttore è da considerarsi totalmente inappropriato e pericoloso e in tal caso il costruttore declina ogni responsabilità.
- Questo apparecchio deve essere usato solo a scopo professionale in un ambiente industriale. Il costruttore non risponderà di danni provocati dall'uso dell'impianto in ambienti domestici.
- L'impianto deve essere utilizzato in ambienti con temperatura compresa tra i -10°C e i +40°C (tra i +14°F e i +104°F). L'impianto deve essere trasportato e immagazzinato in ambienti con temperatura compresa tra i -25°C e i +55°C (tra i -13°F e i 131°F).
- L'impianto deve essere utilizzato in ambienti privi di polvere, acidi, gas o altre sostanze corrosive.
- L'impianto deve essere utilizzato in ambienti con umidità relativa non superiore al 50% a 40°C (104°F). L'impianto deve essere utilizzato in ambienti con umidità relativa non superiore al 90% a 20°C (68°F).
- L'impianto deve essere utilizzato ad una altitudine massima sul livello del mare di 2000m (6500 piedi).

1.2 Protezione personale e di terzi



Assicurarsi che il gruppo di raffreddamento sia spento prima di sconnettere i tubi di mandata e ritorno del liquido refrigerante. Il liquido caldo in uscita potrebbe causare gravi ustioni o scottature.



Provvedere ad un'attrezzatura di pronto soccorso. Non sottovalutare scottature o ferite.



Prima di lasciare il posto di lavoro, porre in sicurezza l'area di competenza in modo da impedire danni accidentali a cose o persone.



1.3 Protezione da shock elettrico

- Uno shock da scarica elettrica può essere mortale.
- Evitare di toccare parti normalmente in tensione interne o esterne all'impianto di saldatura/taglio mentre l'impianto stesso è alimentato (torce, pinze, cavi massa, elettrodi, fili, rulli e bobine sono elettricamente collegati al circuito di saldatura).
- Assicurare l'isolamento elettrico dell'impianto e dell'operatore di saldatura utilizzando piani e basamenti asciutti e sufficientemente isolati dal potenziale di terra e di massa.



1.4 Campi elettromagnetici e interferenze

Classificazione EMC dell'apparecchiatura in accordo con la norma EN/IEC 60974-10 (Vedi targa dati o caratteristiche tecniche)

L'apparecchiatura di classe B è conforme con i requisiti di compatibilità elettromagnetica in ambienti industriali e residenziali, incluse aree residenziali dove l'energia elettrica è fornita da un sistema pubblico a bassa tensione.

L'apparecchiatura di classe A non è intesa per l'uso in aree residenziali dove l'energia elettrica è fornita da un sistema pubblico a bassa tensione. Può essere potenzialmente difficile assicurare la compatibilità elettromagnetica di apparecchiature di classe A in questi aree, a causa di disturbi irradiati e condotti.

Installazione, uso e valutazione dell'area

Questo apparecchio è costruito in conformità alle indicazioni contenute nella norma armonizzata EN60974-10 ed è identificato come di "CLASSE A".

Questo apparecchio deve essere usato solo a scopo professionale in un ambiente industriale.

Il costruttore non risponderà di danni provocati dall'uso dell'impianto in ambienti domestici.



L'utilizzatore deve essere un esperto del settore ed in quanto tale è responsabile dell'installazione e dell'uso dell'apparecchio secondo le indicazioni del costruttore. Qualora vengano rilevati dei disturbi elettromagnetici, spetta all'utilizzatore dell'apparecchio risolvere la situazione avvalendosi dell'assistenza tecnica del costruttore.



In tutti i casi i disturbi elettromagnetici devono essere ridotti fino al punto in cui non costituiscono più un fastidio.



Prima di installare questo apparecchio, l'utilizzatore deve valutare i potenziali problemi elettromagnetici che si potrebbero verificare nell'area circostante e in particolare la salute delle persone circostanti, per esempio: utilizzatori di pace-maker e di apparecchi acustici.

Schermatura

La schermatura selettiva di altri cavi e apparecchi presenti nell'area circostante può alleviare i problemi di interferenza.

La schermatura dell'intero impianto di saldatura (taglio) può essere presa in considerazione per applicazioni speciali.



1.5 Grado di protezione IP

IP23S

- Involucro protetto contro l'accesso a parti pericolose con un dito e contro corpi solidi estranei di diametro maggiore/ uguale a 12,5 mm.
- Involucro protetto contro pioggia a 60° sulla verticale.
- Involucro protetto dagli effetti dannosi dovuti all'ingresso d'acqua, quando le parti mobili dell'apparecchiatura non sono in moto.



1.6 Liquido di raffreddamento

1.6.1 Protezione personale



Prodotto nocivo per ingestione. Può provocare irritazione agli occhi, alle mucose e all'epidermide.



Evitare il contatto utilizzando guanti in gomma.



Evitare schizzi accidentali utilizzando degli occhiali di sicurezza.



Evitare il contatto con la pelle con normali indumenti da lavoro.

1.6.2 Smaltimento



Le perdite o i residui del prodotto, dopo che lo stesso è stato utilizzato nel suo impiego tipico, devono essere trattati in un idoneo impianto di depurazione o se possibile, effettuare il riciclo del prodotto. Non è permesso scaricare il prodotto usato in corsi d'acqua, fossi o sistemi di drenaggio. Il fluido diluito non dovrebbe essere scaricato nelle fognature a meno che non sia permesso dalle normative locali.

2 INSTALLAZIONE



L'installazione può essere effettuata solo da personale esperto ed abilitato dal produttore.



Per l'installazione assicurarsi che il generatore sia scollegato dalla rete di alimentazione.



2.1 Modalità di sollevamento, trasporto e scarico

- L'impianto non è provvisto di elementi specifici per il sollevamento.



Non sottovalutare il peso dell'impianto, vedi caratteristiche tecniche.

Non far transitare o sostare il carico sospeso sopra a persone o cose.



Non lasciare cadere o appoggiare con forza l'impianto o la singola unità.



2.2 Posizionamento dell'impianto

Observare le seguenti norme:

- Facile accesso ai comandi ed ai collegamenti.
- Non posizionare l'attrezzatura in ambienti angusti.
- Non posizionare mai l'impianto su di un piano con inclinazione maggiore di 10° dal piano orizzontale.
- Collocare l'impianto in un luogo asciutto, pulito e con ventilazione appropriata.
- Proteggere l'impianto contro la pioggia battente e contro il sole.

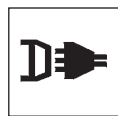

2.3 Allacciamento

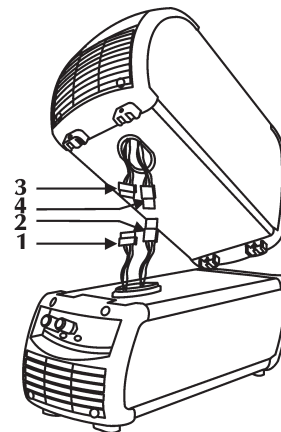

Il gruppo di raffreddamento è provvisto di un connettore 1 per l'allacciamento alla saldatrice.

Il gruppo di raffreddamento è provvisto di un connettore 2 per l'allacciamento alla saldatrice.



Togliere l'alimentazione all'impianto prima di ogni intervento!

- Aprire lo sportello sul cofano inferiore del generatore togliendo le due viti.
- Collegare il connettore maschio 1 del gruppo di raffreddamento al connettore femmina 2 del generatore.
- Collegare il connettore maschio 3 del gruppo di raffreddamento al connettore femmina 4 del generatore.



2.4 Messa in servizio

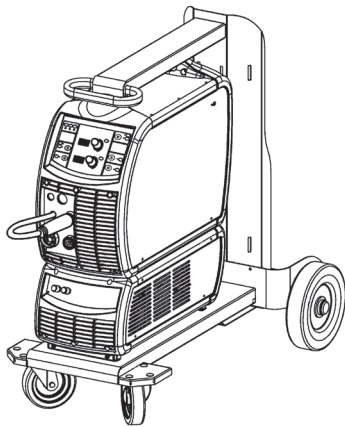



- Appoggiare il WU sopra il GT e fissarlo con le relative 4 viti (1).
- Posizionare il generatore sopra il gruppo di raffreddamento e fissare con le apposite viti.

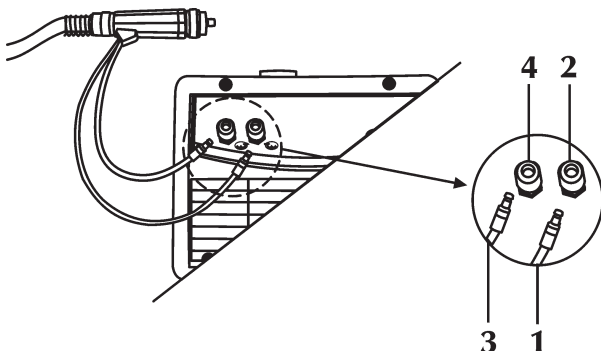

Prima di mettere in funzione il gruppo stesso eseguire le seguenti operazioni:

- Togliere il tappo di chiusura del serbatoio.
- Togliere il tappo ermetico dal canale di imbocco, facendo leva tramite un utensile sul bordo del tappo stesso.
- Aggiungere del liquido se necessario all'interno del serbatoio.
- Tenere il tappo ermetico per eventuali trasporti futuri del gruppo.



- Collegare il tubo di ritorno liquido refrigerante della torcia (1) (colore rosso) all'apposito raccordo/innesto (2) (colore rosso - simbolo ).
- Collegare il tubo di mandata liquido refrigerante della torcia (3) (colore blu) all'apposito raccordo/innesto (4) (colore blu - simbolo ).



Per non danneggiare il gruppo di raffreddamento, montare sempre il tubo by-pass quando la torcia non è collegata ai terminali d'ingresso/uscita liquido refrigerante.





Il riempimento o rabbocco del serbatoio deve essere eseguito con liquido refrigerante cod. 18.91.001.

3 PRESENTAZIONE DELL'IMPIANTO

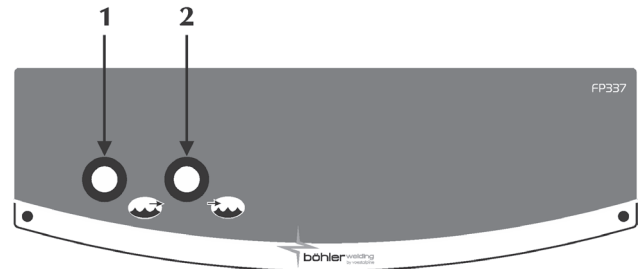
3.1 Pannello frontale



- 1 Raccordo /innesto d'uscita liquido refrigerante.**
 Permette di immettere liquido a bassa temperatura nel circuito di raffreddamento della torcia.
- 2 Raccordo / innesto d'ingresso liquido refrigerante.**
 Permette di immettere liquido, che ha subito il riscaldamento della torcia, nel circuito di raffreddamento interno al WU.

4 MANUTENZIONE



L'impianto deve essere sottoposto ad una manutenzione ordinaria secondo le indicazioni del costruttore.

L'eventuale manutenzione deve essere eseguita esclusivamente da personale qualificato.

Tutti gli sportelli di accesso e servizio e i coperchi devono essere chiusi e ben fissati quando l'apparecchio è in funzione.

L'impianto non deve essere sottoposto ad alcun tipo di modifica. Evitare che si accumuli polvere metallica in prossimità e sulle alette di areazione.



Togliere l'alimentazione all'impianto prima di ogni intervento!



Controllare periodicamente il livello del liquido refrigerante nel serbatoio. Il completo svuotamento del serbatoio e/o la presenza di aria nella pompa possono causare il mancato innesco della stessa.

- Controllare la quantità di liquido nel serbatoio (2/3 di acqua e 1/3 di liquido antigelo).
- Effettuare la pulizia interna utilizzando aria compressa a bassa pressione e pennelli a setola morbida.
- Controllare le connessioni elettriche e tutti i cavi di collegamento.
- Controllare le condizioni dell'elettropompa.
- Controllare lo stato delle connessioni dei tubi.

Ogni sei mesi, cambiare il liquido di raffreddamento e risciacquare i tubi ed il serbatoio con acqua. Cambiare il liquido nel caso dovesse bollire perchè esso perderebbe le proprietà metalliche protettive.



Il riempimento o rabbocco del serbatoio con liquido refrigerante va eseguito con generatore e WU assemblati e posti su di un piano orizzontale.



Il riempimento o rabbocco del serbatoio deve essere eseguito con liquido refrigerante cod. 18.91.001.

L'equipaggiamento non deve essere utilizzato senza liquido di raffreddamento.



Non utilizzare liquidi refrigeranti conduttivi.

In mancanza di detta manutenzione, decadranno tutte le garanzie e comunque il costruttore viene sollevato da qualsiasi responsabilità.

5 DIAGNOSTICA E SOLUZIONI



L'eventuale riparazione o sostituzione di parti dell'impianto deve essere eseguita esclusivamente da personale tecnico qualificato.

La riparazione o la sostituzione di parti dell'impianto da parte di personale non autorizzato comporta l'immediata invalidazione della garanzia del prodotto.

L'impianto non deve essere sottoposto ad alcun tipo di modifica.

Nel caso l'operatore non si attenesse a quanto descritto, il costruttore declina ogni responsabilità.

Mancanza di flusso nel circuito

Causa Mancanza di liquido nel serbatoio.

Soluzione Eseguire il rabbocco.

Causa Aria nel circuito di raffreddamento.

Soluzione Inserire il by-pass sull'innesto di uscita  (colore blu) e sfiatare il circuito idraulico consentendo l'uscita del liquido refrigerante per qualche secondo.

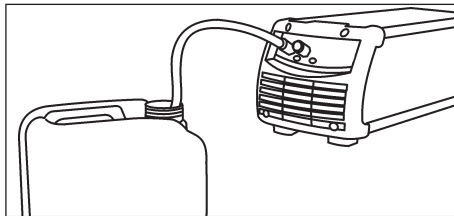

Causa Circuito di raffreddamento ostruito o interrotto.

Soluzione Verificare lo stato delle connessioni (interne al gruppo) del circuito idraulico.

Verificare lo stato del circuito idraulico della torcia.

Verificare lo stato del circuito idraulico del fascio cavi.

Rivolgersi al più vicino centro di assistenza per la riparazione dell'impianto.

Causa Presenza dell'allarme gruppo di raffreddamento.

Soluzione Resettare l'allarme.

Collegare una torcia o il by-pass nelle modalità di funzionamento che prevedono il gruppo di raffreddamento in attività.

Verificare lo stato delle connessioni (interne al gruppo) del circuito idraulico.

Verificare lo stato del circuito idraulico della torcia.

Rivolgersi al più vicino centro di assistenza per la riparazione dell'impianto.

Causa Pompa difettosa.

Soluzione Sostituire il componente danneggiato.

Rivolgersi al più vicino centro di assistenza per la riparazione dell'impianto.

Insufficiente capacità di raffreddamento

Causa Ventilatore difettoso.

Soluzione Sostituire il componente danneggiato.

Rivolgersi al più vicino centro di assistenza per la riparazione dell'impianto.

Causa Pompa difettosa.

Soluzione Sostituire il componente danneggiato.

Rivolgersi al più vicino centro di assistenza per la riparazione dell'impianto.

6 CARATTERISTICHE TECNICHE

	WU 330
Tensione di alimentazione U1	1x400 V
Corrente assorbita I1max	0.5 A
Potenza di raffreddamento (25°C)	1.0 Kw
Tipo di scambiatore	H2O - Aria
Portata nominale (QV)	2.3 l/min
Portata massima (Qvmax)	4.6 l/min
Prevalenza pompa (Hmax)	35 m
Tipo pompa	Rotativa
N° giri massimo	2900 giri/min
Grado di protezione IP	IP23S
Capacità serbatoio	5.5 l
Dimensioni (lpxh)	705x305x250 mm
Peso	15.0 Kg.
Norme di costruzione	EN 60974-2/EN 60974-10

CONFORMITY CERTIFICATE CE

Company
SELCO s.r.l. - Via Palladio, 19 - 35019 ONARA DI TOMBOLO (Padova) - ITALY
Tel. +39 049 9413111 - Fax +39 049 9413311 - E-mail: selco@selcoweld.com - www.selcoweld.com

hereby declares that the equipment:

WU 330

conforms to the EU directives:

2014/35/EU LOW VOLTAGE DIRECTIVE
2014/30/EU EMC DIRECTIVE
2011/65/EU RoHS DIRECTIVE

and that following harmonized standards have been duly applied:

EN 60974-2:2014
EN 60974-10:2015 Class A

Any operation or modification that has not been previously authorized by **SELCO s.r.l.** will invalidate this certificate.

Onara di Tombolo (PADOVA)

Selco s.r.l.



Lino Frasson
Chief Executive

INDEX

1 WARNING	11
1.1 Environment of use.....	11
1.2 User and other persons' protection	11
1.3 Protection from electrical shock	11
1.4 Electromagnetic fields & interferences.....	11
1.5 IP Protection rating.....	12
1.6 Cooling liquid.....	12
1.6.1 Personal protection.....	12
1.6.2 Disposal.....	12
2 INSTALLATION.....	12
2.1 Lifting, transport and unloading procedures	12
2.2 Positioning of the equipment	12
2.3 Connection.....	12
2.4 Installation	13
3 SYSTEM PRESENTATION.....	13
3.1 Front panel	13
4 MAINTENANCE.....	13
5 TROUBLESHOOTING.....	14
6 TECHNICAL SPECIFICATIONS	14

SYMBOLS



Imminent danger of serious body harm and dangerous behaviours that may lead to serious body harm



Important advice to be followed in order to avoid minor injuries or damage to property



Technical notes to facilitate operations

1 WARNING



Before performing any operation on the machine, make sure that you have thoroughly read and understood the contents of this booklet.

Do not perform modifications or maintenance operations which are not prescribed.

The manufacturer cannot be held responsible for damages to persons or property caused by misuse or non-application of the contents of this booklet by the user.



Please consult qualified personnel if you have any doubts or difficulties in using the equipment.



1.1 Environment of use

- All equipment shall be used exclusively for the operations for which it was designed, in the ways and ranges stated on the rating plate and/or in this booklet, according to the national and international directives regarding safety. Other uses than the one expressly declared by the manufacturer shall be considered totally inappropriate and dangerous and in this case the manufacturer disclaims all responsibility.
- This equipment shall be used for professional applications only, in industrial environments.
The manufacturer shall not be held responsible for any damages caused by the use of the equipment in domestic environments.
- The equipment must be used in environments with a temperature between -10°C and $+40^{\circ}\text{C}$ (between $+14^{\circ}\text{F}$ and $+104^{\circ}\text{F}$).
The equipment must be transported and stored in environments with a temperature between -25°C and $+55^{\circ}\text{C}$ (between -13°F and 131°F).
- The equipment must be used in environments free from dust, acid, gas or any other corrosive substances.
- The equipment shall not be used in environments with a relative humidity higher than 50% at 40°C (104°F).
The equipment shall not be used in environments with a relative humidity higher than 90% at 20°C (68°F).
- The system must not be used at an higher altitude than 2,000 metres (6,500 feet) above sea level.

1.2 User and other persons' protection



Ensure the cooling unit is switched off before disconnecting the delivery and return pipes of the cooling liquid. The hot liquid coming out of the pipes might cause burning or scalding.



Keep a first aid kit ready for use.
Do not underestimate any burning or injury.



Before leaving work, make the area safe in order to avoid accidental damage to people or property.



1.3 Protection from electrical shock

- Electric shocks can kill you.
- Avoid touching live parts both inside and outside the welding/cutting system while this is active (torches, guns, earth cables, electrodes, wires, rollers and spools are electrically connected to the welding circuit).
- Ensure the system and the welder are insulated electrically by using dry bases and floors that are sufficiently insulated from the earth.



1.4 Electromagnetic fields & interferences

EMC equipment classification in accordance with EN/IEC 60974-10 (See rating plate or technical data)

Class B equipment complies with electromagnetic compatibility requirements in industrial and residential environments, including residential locations where the electrical power is provided by the public low-voltage supply system.

Class A equipment is not intended for use in residential locations where the electrical power is provided by the public low-voltage supply system. There may be potential difficulties in ensuring electromagnetic compatibility of class A equipment in those locations, due to conducted as well as radiated disturbances.

Installation, use and area examination

This equipment is manufactured in compliance with the requirements of the EN60974-10 harmonized standard and is identified as "CLASS A" equipment.

This unit must be used for professional applications only, in industrial environments.

The manufacturer shall not be held responsible for any damage caused by use in domestic environments.



The user must be an expert in the activity and as such is responsible for installation and use of the equipment according to the manufacturer's instructions.

If any electromagnetic interference is noticed, the user must solve the problem, if necessary with the manufacturer's technical assistance.



In any case electromagnetic interference must be reduced until it is not a nuisance any longer.



Before installing this equipment, the user must evaluate the potential electromagnetic problems that may arise in the surrounding area, considering in particular the health conditions of the persons in the vicinity, for example of persons fitted with pace-makers or hearing aids.

Shielding

The selective shielding of other cables and equipment present in the surrounding area may reduce the problems due to electromagnetic interference. The shielding of the entire welding (cutting) equipment can be taken in consideration for special applications.



1.5 IP Protection rating

IP23S

- Enclosure protected against access to dangerous parts by fingers and against ingress of solid foreign bodies with diameter greater than/equal to 12.5 mm
- Enclosure protected against rain at an angle of 60°.
- Enclosure protected against harmful effects due to the ingress of water when the moving parts of the equipment are not operating.



1.6 Cooling liquid

1.6.1 Personal protection



Product harmful if swallowed. Can cause irritation to eyes, mucous membranes and skin.



Use rubber gloves to prevent contact.



Use safety goggles to prevent accidental splashes.



Wear ordinary work clothes to prevent contact with the skin.

1.6.2 Disposal



Any leaks or remains of product, after it has been used, must be treated in a suitable purification plant or recycled if possible. Do not discharge the used product into watercourses, ditches or drainage systems. The diluted fluid should not be discharged into the sewers unless permitted by the local regulations.

2 INSTALLATION



Installation should be performed only by expert personnel authorised by the manufacturer.



During installation, ensure that the power source is disconnected from the mains.



2.1 Lifting, transport and unloading procedures

- The system is not equipped with specific lifting gear.



Do not underestimate the weight of the equipment: see technical specifications.

Do not move or position the suspended load above persons or things.



Do not drop or apply undue pressure on the equipment.



2.2 Positioning of the equipment

Keep to the following rules:

- Provide easy access to the equipment controls and connections.
- Do not position the equipment in very small spaces.
- Do not place the equipment on surfaces with inclination exceeding 10° from to the horizontal plane.
- Position the equipment in a dry, clean and suitably ventilated place.
- Protect the equipment against pouring rain and sun.



2.3 Connection

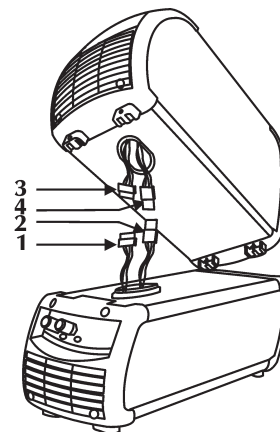

The cooling unit is provided with a connector 1 for connection to the power source.

The cooling unit is provided with a connector 2 for connection to the power source.



Disconnect the power supply before every operation!

- Open the door on the bottom of the power source by removing the two screws.
- Connect the male connector 1 of the cooling unit to the female connector 2 of the power source.
- Connect the male connector 3 of the cooling unit to the female connector 4 of the power source.



2.4 Installation

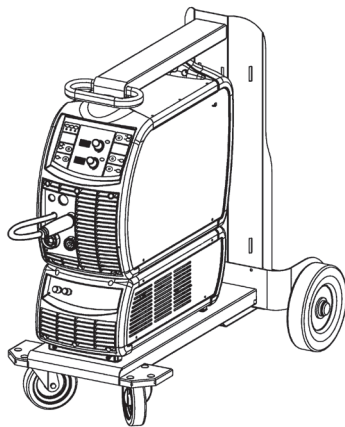



- Put the WU on the GT and block it with the 4 screws (1).
- Position the power source above the cooling unit and secure it by means of the screws.

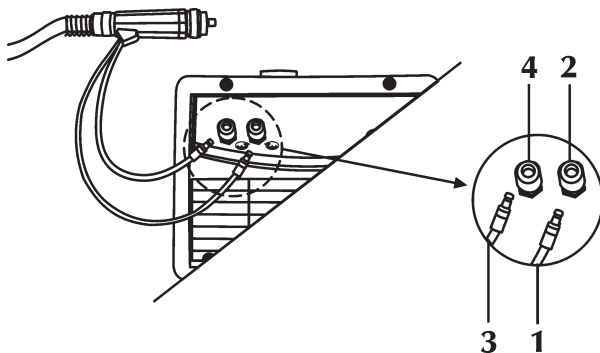

Perform the following operations before starting the unit:

- Remove the refill neck cap.
- Remove the sealing cap from the refill neck, levering by means of a tool on the edge of the cap.
- Fill the tank with cooling liquid if necessary.
- Keep apart the sealing cap for future transport of the unit.



- Connect the red hose of the torch (1) to the appropriate inlet quick connector (2) (red colour - symbol ).
- Connect the blue hose of the torch (3) to the appropriate outlet quick connector (4) (blue colour - symbol ).



In order to avoid any damage the cooling unit, always fit the by-pass pipe when the torch is not connected to the cooling liquid inlet/outlet terminals.



Filling or topping up of the tank must be performed with cooling liquid, code 18.91.001.

3 SYSTEM PRESENTATION

3.1 Front panel

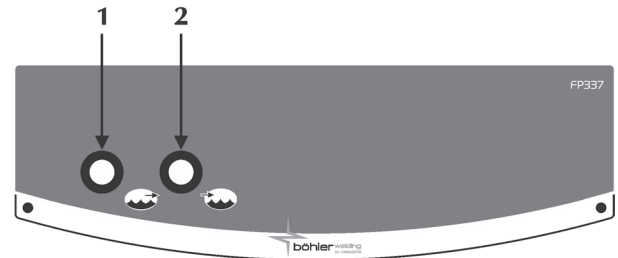

1 Cooling liquid outlet connector



To supply low temperature liquid into the torch cooling circuit.

2 Cooling liquid inlet connector



To return the liquid that has been heated by the torch into the cooling circuit inside the WU.

4 MAINTENANCE



Routine maintenance must be carried out on the system according to the manufacturer's instructions.

Any maintenance operation must be performed by qualified personnel only.

When the equipment is working, all the access and operating doors and covers must be closed and locked.

Unauthorized changes to the system are strictly forbidden.

Prevent conductive dust from accumulating near the louvers and over them.



Disconnect the power supply before every operation!



Periodically check the cooling liquid level in the tank. If the tank is completely empty and/or there is air in the cooling circuit, this may cause malfunctions of the pump.

- Check the quantity of liquid in the tank (2/3 water and 1/3 antifreeze liquid).
- Clean the unit inside by means of low-pressure compressed air and soft bristle brushes.
- Check the electrical connections and all the connection cables.
- Check the condition of the electric pump.
- Check the state of the hose connections.

Every six months, change the cooling liquid and wash out the hoses and tank with water. Change the liquid in cases, where it should boil, since it would lose its protective properties.



Filling or topping up of the tank with cooling liquid must be performed with the power source and WU assembled and positioned on a horizontal surface.



Filling or topping up of the tank must be performed with cooling liquid, code 18.91.001.

The equipment must not be used without cooling liquid.



Do not use conductive cooling liquids.

Failure to carry out the above maintenance will invalidate all warranties and exempt the manufacturer from all liability.

5 TROUBLESHOOTING



The repair or replacement of any parts in the system must be carried out only by qualified personnel.

The repair or replacement of any parts in the system by unauthorized personnel will invalidate the product warranty. The system must not be modified in any way.

The manufacturer disclaims any responsibility if the user does not follow these instructions.

No liquid flow in circuit

Cause No liquid in the tank.
Solution Refill.

Cause Air in cooling circuit.
Solution Connect the by-pass to the outlet connection  (blue colour) and bleed the hydraulic circuit allowing the cooling fluid to emerge for a few seconds.

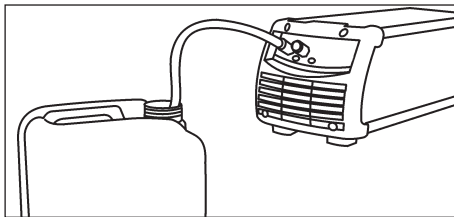

Cause Cooling circuit blocked or broken.
Solution Check the state of the connections (inside the unit) of the hydraulic circuit.
Check the state of the torch's hydraulic circuit.
Check the condition of the coolant circuit in the cable bundle.
Contact the nearest service centre to have the system repaired.

Cause Presence of the cooling unit alarm.
Solution Reset the alarm.
Connect a torch or the by-pass in the operating modes requiring the cooling unit to be active.
Check the state of the connections (inside the unit) of the hydraulic circuit.
Check the state of the torch's hydraulic circuit.
Contact the nearest service centre to have the system repaired.

Cause Faulty pump.
Solution Replace the faulty component.
Contact the nearest service centre to have the system repaired.

Insufficient cooling capacity

Cause Faulty fan.
Solution Replace the faulty component.
Contact the nearest service centre to have the system repaired.

Cause Faulty pump.
Solution Replace the faulty component.
Contact the nearest service centre to have the system repaired.

6 TECHNICAL SPECIFICATIONS

	WU 330
Power supply voltage U1	1x400 V
Input current I1 max	0.5 A
Cooling power (25°C)	1.0 Kw
Type of exchanger	H2O - Air
Nominal flow rate (QV)	2.3 l/min
Maximum flow rate (Qvmax)	4.6 l/min
Pump total head (Hmax)	35 m
Pump type	Centrifugal
Maximum rpm	2900 rpm/min
IP Protection rating	IP23S
Tank capacity	5.5 l
Dimensions (lxdxh)	705x305x250 mm
Weight	15.0 Kg.
Manufacturing standards	EN 60974-2/EN 60974-10

KONFORMITÄTSERKLÄRUNG CE

Die Firma

SELCO s.r.l. - Via Palladio, 19 - 35019 ONARA DI TOMBOLO (Padova) - ITALY

Tel. +39 049 9413111 - Fax +39 049 9413311 - E-Mail: selco@selcoweld.com - www.selcoweld.com

erklärt, dass das Gerät Typ

WU 330

den folgenden EU Richtlinien entspricht:

2014/35/EU

LOW VOLTAGE DIRECTIVE

2014/30/EU

EMC DIRECTIVE

2011/65/EU

RoHS DIRECTIVE

dass die folgenden harmonisierten Normen angewendet wurden

EN 60974-2:2014

EN 60974-10:2015 Class A

Jede von der Firma **SELCO s.r.l.** nicht genehmigte Änderung hebt die Gültigkeit dieser Erklärung auf.

Onara di Tombolo (PADOVA)

Selco s.r.l.



Lino Frasson
Chief Executive

INDEX

1	WARNUNG.....	17
1.1	Arbeitsumgebung.....	17
1.2	Persönlicher Schutz und Schutz Dritter.....	17
1.3	Schutz vor Elektrischem Schlag.....	17
1.4	Elektromagnetische Felder und Störungen.....	17
1.5	Schutzart IP.....	18
1.6	Kühlflüssigkeit.....	18
1.6.1	Personenschutz.....	18
1.6.2	Entsorgung.....	18
2	INSTALLATION.....	18
2.1	Heben, Transportieren und Abladen.....	18
2.2	Aufstellen der Anlage.....	18
2.3	Anschluss.....	18
2.4	Inbetriebnahme.....	19
3	PRÄSENTATION DER ANLAGE.....	19
3.1	Frontplatte.....	19
4	WARTUNG.....	19
5	FEHLERSUCHE.....	20
6	TECHNISCHE DATEN.....	20

SYMBOLE



Drohende Gefahren, die schwere Verletzungen verursachen und gefährliche Verhaltensweisen, die zu schweren Verletzungen führen können



Verhaltensweisen, die leichte Verletzungen oder Sachschäden verursachen könnten



Die mit diesem Symbol gekennzeichneten Anmerkungen sind technischer Art und erleichtern die Arbeitsschritte

1 WARNUNG



Vor Arbeitsbeginn lesen Sie das Anleitsheft sorgfältig durch und vergewissern Sie sich, ob Sie alles richtig verstanden haben. Nehmen Sie keine Änderungen vor und führen Sie keine hier nicht beschriebenen Instandhaltungsarbeiten durch.

Der Hersteller haftet nicht für Personen- oder Sachschäden, die durch unsachgemäßen Gebrauch oder Nichteinhaltung der Vorgaben dieser Anleitung seitens des Benutzers verursacht werden.



Bei Fragen oder Unklarheiten im Umgang mit dem Gerät wenden Sie sich an Fachpersonal.



1.1 Arbeitsumgebung

- Die gesamte Anlage darf ausschließlich für den Zweck verwendet werden, für den sie konzipiert wurde, auf die Art und in dem Umfang, der auf dem Leistungsschild und/oder im vorliegenden Handbuch festgelegt ist und gemäß den nationalen und internationalen Sicherheitsvorschriften. Ein anderer Verwendungszweck, als der ausdrücklich vom Hersteller angegebene, ist unsachgemäß und gefährlich. Der Hersteller übernimmt in solchen Fällen keinerlei Haftung.
- Dieses Gerät darf nur für gewerbliche Zwecke im industriellen Umfeld angewendet werden.
Der Hersteller haftet nicht für Schäden, die durch den Gebrauch der Anlage im Haushalt verursacht wurden.
- Die Anlage darf nur bei Umgebungstemperaturen zwischen -10°C und $+40^{\circ}\text{C}$ (zwischen $+14^{\circ}\text{F}$ und $+104^{\circ}\text{F}$) benutzt werden.
Die Anlage darf nur bei Umgebungstemperaturen zwischen -25°C und $+55^{\circ}\text{C}$ (zwischen -13°F und 131°F) befördert und gelagert werden.
- Die Anlage darf nur in einer Umgebung benutzt werden, die frei von Staub, Säure, Gas und ätzenden Substanzen ist.
- Die Anlage darf nicht in einer Umgebung mit einer relativen Luftfeuchte über 50% bei 40°C (104°F) benutzt werden.
Die Anlage darf nicht in einer Umgebung mit einer relativen Luftfeuchte über 90% bei 20°C (68°F) benutzt werden.
- Die Anlage darf nicht in einer Höhe von mehr als 2000m über NN (6500 Fuß) benutzt werden.

1.2 Persönlicher Schutz und Schutz Dritter



Stellen Sie sicher, dass das Kühlaggregat ausgeschaltet ist, bevor Sie die Vor- und Rücklaufleitungen der Kühlflüssigkeit trennen.

Die austretende heiße Flüssigkeit kann schwere Verbrennungen verursachen.



Halten Sie einen Verbandskasten griffbereit. Verbrennungen oder Verletzungen sind nicht zu unterschätzen.



Vor dem Verlassen des Arbeitsplatzes muss dieser gesichert werden, um Personen- und Sachschäden zu vermeiden.



1.3 Schutz vor Elektrischem Schlag

- Ein Stromschlag kann tödlich sein.
- Üblicherweise unter Spannung stehende Innen- oder Außenteile der gespeisten Schweiß-/Schneidanlage nicht berühren (Brenner, Zangen, Massekabel, Elektroden, Draht, Rollen und Spulen sind elektrisch mit dem Schweißstromkreis verbunden).
- Die elektrische Isolierung der Anlage und des Schweißers durch Benutzung trockener und ausreichend vom Erd- und Massepotential isolierter Flächen und Untergestelle sicherstellen.



1.4 Elektromagnetische Felder und Störungen

EMV Anlagenklassifizierung in Übereinstimmung mit EN/IEC 60974-10 (Siehe Typenschild oder Technische Daten)

Anlagen der Klasse B entsprechen den elektromagnetischen Kompatibilitätsanforderungen in Mischgebieten, einschließlich Wohngebieten, in denen die elektrische Leistung von dem öffentlichen Niederspannungsversorgungsnetz geliefert wird.

Anlagen der Klasse A sind nicht für die Nutzung in Wohngebieten konzipiert, in denen die elektrische Leistung vom öffentlichen Niederspannungsversorgungsnetz geliefert wird. Es können potenzielle Schwierigkeiten beim Sicherstellen der elektromagnetischen Kompatibilität von Anlagen der Klasse A in diesen Umgebungen auftreten, aufgrund der ausgestrahlten Störgrößen.

Installation, Gebrauch und Bewertung des Bereichs

Dieses Gerät ist in Übereinstimmung mit den Angaben der harmonisierten Norm EN60974-10 hergestellt und als Gerät der "KLASSE A" gekennzeichnet.

Dieses Gerät darf nur für gewerbliche Zwecke im industriellen Umfeld angewendet werden.

Der Hersteller haftet nicht für Schäden, die durch den Gebrauch der Anlage im Haushalt verursacht wurden.



Der Benutzer muss ein erfahrener Fachmann auf dem Gebiet sein und ist als solcher für die Installation und den Gebrauch des Geräts gemäß den Herstelleranweisungen verantwortlich.

Wenn elektromagnetische Störungen festgestellt werden, muss der Benutzer des Gerätes das Problem lösen, wenn notwendig mit Hilfe des Kundendienstes des Herstellers.



In jedem Fall müssen die elektromagnetischen Störungen soweit reduziert werden, bis sie keine Belästigung mehr darstellen.



Bevor das Gerät installiert wird, muss der Benutzer die möglichen elektromagnetischen Probleme, die sich im umliegenden Bereich ergeben können, und insbesondere die Gesundheit, der sich in diesem Bereich aufhaltenden Personen - Träger von Schrittmachern und Hörgeräten - prüfen.

Abschirmung

Durch die selektive Abschirmung anderer Kabel und Geräte im umliegenden Bereich lassen sich die Probleme durch elektromagnetische Störungen reduzieren. Die Abschirmung der gesamten Schweißanlage (Schneidanlage) kann in besonderen Fällen in Betracht gezogen werden.



1.5 Schutzart IP

IP23S

- Gehäuse mit Schutz gegen Berührung gefährlicher Teile mit den Fingern und vor dem Eindringen von Fremdkörpern mit einem Durchmesser größer/gleich 12,5 mm.
- Gehäuse mit Schutz gegen Sprühwasser bis zu einem Winkel von 60° in Bezug auf die Senkrechte.
- Gehäuse mit Schutz gegen Schäden durch eindringendes Wasser, wenn die beweglichen Teile der Anlage im Stillstand sind.



1.6 Kühlflüssigkeit

1.6.1 Personenschutz



Eine Einnahme des Produktes ist schädlich. Es kann Augen, Schleimhäute und die Haut reizen.



Tragen Sie Gummihandschuhe, um einen Kontakt zu vermeiden.



Setzen Sie eine Schutzbrille auf, um sich vor Spritzern zu schützen.



Tragen Sie gebräuchliche Arbeitskleidung, um Hautkontakt zu vermeiden.

1.6.2 Entsorgung



Ausgelaufene Kühlflüssigkeit, Produktreste und gebrauchte Kühlflüssigkeit müssen in einer geeigneten Kläranlage behandelt oder, falls möglich, recycled werden. Das gebrauchte Produkt nicht in Gewässern, Gräben oder in Entwässerungssystemen entsorgen. Die verdünnte Flüssigkeit nicht in die Kanalisation geben, außer es wird von den örtlichen Vorschriften erlaubt.

2 INSTALLATION



Die Installation darf nur von erfahrener und vom Hersteller berechtigtem Personal ausgeführt werden.



Stellen Sie sicher, dass während der Installation der Generator vom Versorgungsnetz getrennt ist.



2.1 Heben, Transportieren und Abladen

- Die Anlage ist nicht mit einer speziellen Hebevorrichtung ausgestattet.



Unterschätzen Sie nicht das Gewicht der Anlage: siehe Technische Daten.

Bewegen oder platzieren Sie die angehängte Last nicht über Personen oder Gegenständen.



Lassen Sie das Gerät/die Anlage nicht fallen und üben Sie keinen übermäßigen Druck auf die Anlage aus.



2.2 Aufstellen der Anlage

Folgende Vorschriften beachten:

- Sorgen Sie für freien Zugang zu den Bedienelementen und Anschlüssen.
- Stellen Sie die Anlage nicht in engen Räumen auf.
- Stellen Sie die Anlage nie auf einer Fläche mit einer Neigung von mehr als 10° auf.
- Stellen Sie die Anlage an einem trockenen und sauberen Ort mit ausreichender Belüftung auf.
- Schützen Sie die Anlage vor strömenden Regen und Sonne.

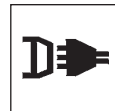

2.3 Anschluss

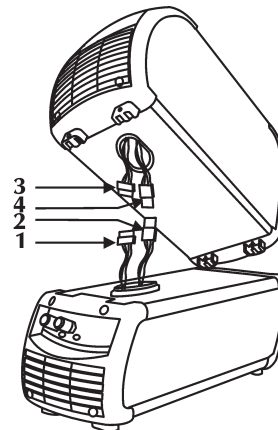

Das Kühlaggregat ist mit einem Stecker 1 für den Stromanschluss an den Generator versehen.

Das Kühlaggregat ist mit einem Stecker 2 für den Stromanschluss an den Generator versehen.



Vor jedem Eingriff ist die Anlage vom Stromnetz zu trennen.

- Die untere Klappe des Generators durch Lösen der zwei Schrauben öffnen.
- Den Stecker 1 des Kühlaggregats mit der Steckdose 2 des Generators verbinden.
- Den Stecker 3 des Kühlaggregats mit der Steckdose 4 des Generators verbinden.



2.4 Inbetriebnahme

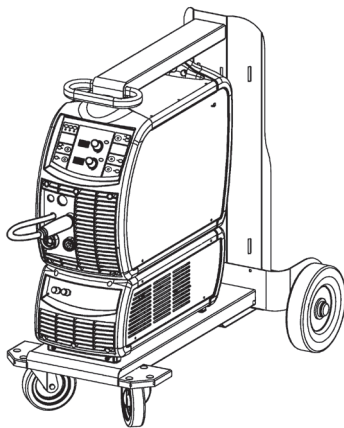



- Den WU auf den GT legen und mit den 4 Schrauben befestigen (1).
- Den Generator auf dem Kühlaggregat platzieren und mittels Schrauben befestigen.

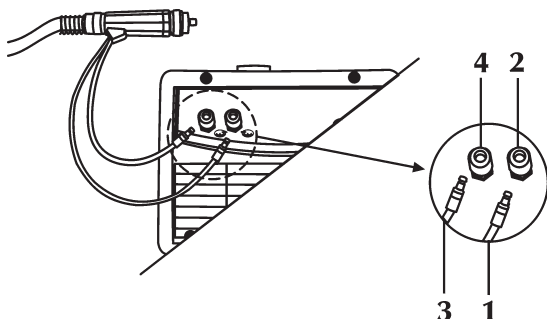

Führen Sie folgende Schritte vorm Einschalten der Anlage durch:

- Den Tankverschluss entfernen.
- Den Dichtstopfen von der Einfüllöffnung entfernen, indem Sie den Rand des Stopfens mit einem Werkzeug anheben.
- Gegebenenfalls Kühlflüssigkeit im Tank nachfüllen.
- Bewahren Sie den Dichtstopfen für spätere Transporte der Anlage auf.



- Den roten Schlauch (Rücklauf der Kühlflüssigkeit) des Brenners (1) mit dem entsprechenden Schnellverbinder (2) (rot - Symbol ) verbinden.
- Den blauen Schlauch (Vorlauf der Kühlflüssigkeit) des Brenners (3) mit dem entsprechenden Schnellverbinder (4) (blau - Symbol ) verbinden.



Um Schäden am Kühlaggregat zu vermeiden, montieren Sie immer den Bypass-Schlauch, wenn der Brenner nicht mit den Kühlmittelanschlüssen (Rücklauf A3, Vorlauf A4) verbunden ist.



Das Füllen oder Nachfüllen des Tanks muss mit Kühlflüssigkeit Code 18.91.001 ausgeführt werden.

3 PRÄSENTATION DER ANLAGE

3.1 Frontplatte

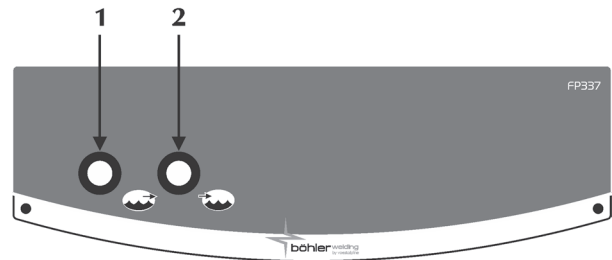

1 Anschluss Kühlmittelvorlauf



Ermöglicht die Zuführung von kalter Flüssigkeit in den Kühlkreislauf des Brenners.

2 Anschluss Kühlmittelrücklauf



Ermöglicht die Rückführung der im Schweißbrenner erwärmten Flüssigkeit in den Kühlkreislauf der WU.

4 WARTUNG



Die regelmäßige Wartung der Anlage muss nach den Angaben des Herstellers erfolgen.

Jeder Wartungseingriff darf nur von Fachpersonal ausgeführt werden.

Wenn das Gerät in Betrieb ist, müssen alle Zugangs-, Wartungstüren und Abdeckungen geschlossen und verriegelt sein.

Unautorisierte Eingriffe und Veränderungen an der Anlage sind strengstens verboten.

Vermeiden Sie Ansammlungen von Metallstaub in der Nähe und über den Lüftungsschlitzen.



Trennen Sie die Anlage von der Stromzufuhr vor jedem Wartungseingriff.



Den Kühlflüssigkeitsstand im Behälter regelmäßig prüfen. Wenn der Kühlflüssigkeitsbehälter ganz leer ist und/oder Luft im Kühlkreislauf vorhanden ist, kann dies zu Funktionsstörungen der Pumpe führen.

- Die Flüssigkeitsmenge im Tank überprüfen (2/3 Wasser und 1/3 Frostschutzmittel).
- Das Innere der Anlage mittels Druckluft mit niederem Druck und weichen Pinseln reinigen.
- Elektrische Verbindungen und Anschlusskabel prüfen.
- Den Zustand der Elektropumpe überprüfen.
- Den Zustand der Schlauchverbindungen überprüfen.

Alle sechs Monate die Kühlflüssigkeit wechseln und die Schläuche und den Tank mit Wasser säubern. Sollte die Kühlflüssigkeit einmal gekocht haben, ist sie auszutauschen, da sie sonst ihre Korrosionsschutzeigenschaften verliert.



Das Füllen oder Nachfüllen des Tanks mit Kühlflüssigkeit darf nur mit zusammengebautem Generator und WU und auf einer horizontalen Fläche erfolgen.



Das Füllen oder Nachfüllen des Tanks muss mit Kühlflüssigkeit Code 18.91.001 ausgeführt werden.
Die Anlage darf nie ohne Kühlflüssigkeit eingesetzt werden.



Keine leitfähigen Kühlflüssigkeiten verwenden.

Durch Unterlassung der oben genannten Wartung wird jegliche Garantie aufgehoben und der Hersteller wird von jeglicher Haftung befreit.

5 FEHLERSUCHE



Das Reparieren oder Austauschen von Anlageteilen darf ausschließlich von Fachpersonal ausgeführt werden.

Das Reparieren oder Austauschen von Anlageteilen durch unautorisiertes Personal hebt die Produktgarantie auf. Die Anlage darf keinen Änderungen unterzogen werden.

Der Hersteller übernimmt keinerlei Haftung, falls sich der Benutzer nicht an diese Vorschriften hält.

Kein Durchfluss im Kühlkreislauf

Ursache Kein Kühlmittel im Tank.
Abhilfe Nachfüllen.

Ursache Luft im Kühlmittelkreislauf.
Abhilfe Verbinden Sie den Bypass-Schlauch mit dem Anschluss  (blau) und zapfen Sie den Kühlmittelkreislauf an, um die Kühlflüssigkeit für einige Sekunden austreten zu lassen.

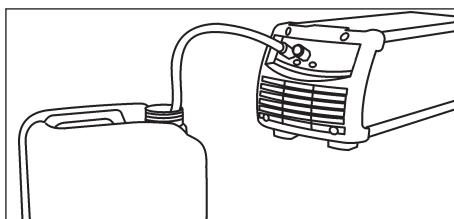

Ursache Kühlmittelkreislauf verstopft oder unterbrochen.
Abhilfe Überprüfen Sie den Zustand der Verbindungen (innerhalb der Kühleinheit) des Kühlmittelkreislaufes.
Überprüfen Sie den Zustand des Brenner-Kühlmittelkreislaufes.
Überprüfen Sie den Zustand des Kabelbündel-Kühlmittelkreislaufes.
Anlage von der nächstgelegenen Kundendienststelle reparieren lassen.

Ursache Alarm Kühleinheit steht an.
Abhilfe Den Alarm zurücksetzen.
Schließen Sie in den Betriebsarten, die eine aktive Kühleinheit erfordern, den Brenner oder Bypass-Schlauch an.

Überprüfen Sie den Zustand der Verbindungen (innerhalb der Kühleinheit) des Kühlmittelkreislaufes.
Überprüfen Sie den Zustand des Brenner-Kühlmittelkreislaufes.

Anlage von der nächstgelegenen Kundendienststelle reparieren lassen.

Ursache Pumpe defekt.
Abhilfe Schadhafes Teil ersetzen.

Anlage von der nächstgelegenen Kundendienststelle reparieren lassen.

Unzureichende Kühlkapazität

Ursache Gebläse defekt.
Abhilfe Schadhafes Teil ersetzen.

Anlage von der nächstgelegenen Kundendienststelle reparieren lassen.

Ursache Pumpe defekt.
Abhilfe Schadhafes Teil ersetzen.

Anlage von der nächstgelegenen Kundendienststelle reparieren lassen.

6 TECHNISCHE DATEN

	WU 330
Versorgungsspannung U1	1x400 V
Stromaufnahme I1max	0.5 A
Kälteleistung (25°C)	1.0 Kw
Austauschertyp	H2O - Luft
Nennförderleistung (QV)	2.3 l/min
Höchstförderleistung (Qvmax)	4.6 l/min
Pumpenförderhöhe (Hmax)	35 m
Pumpentyp	Kreisel
Max. Drehzahl	2900 min
Schutzart IP	IP23S
Fassungsvermögen des Tanks	5.5 l
Abmessungen (LxBxH)	705x305x250 mm
Gewicht	15.0 Kg.
Konstruktionsnormen	EN 60974-2/EN 60974-10

DECLARATION DE CONFORMITE CE

Société

SELCO s.r.l. - Via Palladio, 19 - 35019 ONARA DI TOMBOLO (Padova) - ITALIE
Tél. +39 049 9413111 - Fax +39 049 9413311 - E-mail : selco@selcoweld.com - www.selcoweld.com

déclare que l'appareil type :

WU 330

est conforme aux directives EU :

2014/35/EU LOW VOLTAGE DIRECTIVE
2014/30/EU EMC DIRECTIVE
2011/65/EU RoHS DIRECTIVE

et que les normes ci-contre ont été appliquées :

EN 60974-2:2014
EN 60974-10:2015 Class A

Toute intervention ou modification non autorisée préalablement par **SELCO s.r.l.** annulera la validité de cette déclaration.

Onara di Tombolo (PADOVA)

Selco s.r.l.



Lino Frasson
Président Directeur Général

INDEX GENERAL

1 AVERTISSEMENT	23
1.1 Environnement d'utilisation	23
1.2 Protection individuelle et de l'entourage	23
1.3 Protection contre les décharges électriques.....	23
1.4 Champs électromagnétiques et interférences	23
1.5 Degré de protection IP	24
1.6 Liquide de refroidissement.....	24
1.6.1 Protection individuelle	24
1.6.2 Élimination	24
2 INSTALLATION.....	24
2.1 Mode de soulèvement, de transport et de déchargement	24
2.2 Installation de l'appareil.....	24
2.3 Branchement et raccordement.....	24
2.4 Mise en service.....	25
3 PRÉSENTATION DE L'APPAREIL	25
3.1 Panneau frontal.....	25
4 ENTRETIEN	25
5 INCIDENTS	26
6 CARACTÉRISTIQUES TECHNIQUES.....	26

SYMBOLOLOGIE



Dangers imminents qui causent de graves lésions et comportements risqués qui pourraient causer de graves lésions



Comportements qui pourraient causer des lésions sans gravité ou des dommages aux biens



Les notes précédées par ce symbole sont de caractère technique et facilitent les opérations

1 AVERTISSEMENT



Avant de commencer toute opération, assurez-vous d'avoir bien lu et bien compris ce manuel. N'apportez pas de modification et n'effectuez pas d'opération de maintenance si elles ne sont pas indiquées dans ce manuel.

Le fabricant n'est pas responsable des dommages causés aux personnes ou aux objets en cas de non-respect ou de mise en pratique incorrecte des instructions de ce manuel.



Prière de consulter du personnel qualifié en cas de doute ou de problème sur l'utilisation de l'installation, même si elle n'est pas décrite ici.



1.1 Environnement d'utilisation

- Chaque installation ne doit être utilisée que dans le but exclusif pour lequel elle a été conçue, de la façon et dans les limites prévues sur la plaque signalétique et/ou dans ce manuel, selon les directives nationales et internationales relatives à la sécurité. Un usage autre que celui expressément déclaré par le fabricant doit être considéré comme inapproprié et dangereux et décharge ce dernier de toute responsabilité.
- Cet appareil ne doit être utilisé que dans un but professionnel, dans un environnement industriel.
Le fabricant n'est pas responsable des dommages causés en cas d'usage domestique.
- L'installation doit être utilisée dans un local dont la température est comprise entre -10 et +40°C (entre +14 et +104°F). L'installation doit être transportée et stockée dans un local dont la température est comprise entre -25 et +55°C (entre -13 et 131°F).
- L'installation doit être utilisée dans un local sans poussière, ni acide, ni gaz ou autres substances corrosives.
- L'installation ne doit pas être utilisée dans un local dont le taux d'humidité dépasse 50% à 40°C (104°F). L'installation ne doit pas être utilisée dans un local dont le taux d'humidité dépasse 90% à 20°C (68°F).
- L'installation ne doit pas être utilisée à une altitude supérieure à 2 000 m au dessus du niveau de la mer (6 500 pieds).

1.2 Protection individuelle et de l'entourage



S'assurer que le groupe de refroidissement est éteint avant de déconnecter les tuyaux d'arrivée et de retour du liquide réfrigérant. Le liquide chaud en s'échappant pourrait provoquer des brûlures graves.



Avoir à disposition une trousse de secours.
Ne pas sous-estimer les brûlures ou les blessures.



Avant de quitter le poste de travail, sécuriser la zone afin d'empêcher tout risque d'accident ou de dommages aux personnes ou aux biens.



1.3 Protection contre les décharges électriques

- Une décharge électrique peut être mortelle.
- Éviter de toucher les parties normalement sous tension à l'intérieur ou à l'extérieur de l'installation de soudage/coupage quand cette dernière est alimentée (les torches, les pinces, les câbles de masse, les électrodes, les fils, les galets et les bobines sont branchés au circuit de soudage).
- Garantir l'isolation de l'installation et de l'opérateur en utilisant des sols et des plans secs et suffisamment isolés de la terre.



1.4 Champs électromagnétiques et interférences

Compatibilité électromagnétique CEM selon la norme EN/IEC 60974-10 (Se reporter à la plaque signalétique ou aux caractéristiques techniques)

Le matériel de classe B est conforme aux exigences de compatibilité électromagnétique en milieu industriel et résidentiel, y compris en environnement résidentiel où l'alimentation électrique est distribuée par un réseau public basse tension.

Le matériel de classe A n'est pas conçu pour être utilisé en environnement résidentiel où l'alimentation électrique est distribuée par un réseau public basse tension. Il pourrait être difficile d'assurer la compatibilité électromagnétique d'appareils de classe A dans de tels environnements, en raison de perturbations par rayonnement ou conduction.

Installation, utilisation et évaluation de la zone

Ce matériel a été fabriqué conformément aux dispositions relatives à la norme harmonisée EN60974-10 et est considéré comme faisant partie de la " CLASSE A ".

Cet appareil doit être utilisé exclusivement dans un but professionnel, dans un environnement industriel.

Le fabricant n'est pas responsable des dommages causés en cas d'usage domestique.



L'utilisateur, qui doit être un expert dans le domaine, est responsable en tant que tel de l'installation et de l'utilisation de l'appareil selon les instructions du constructeur.

Si des perturbations électromagnétiques apparaissent, il est de la responsabilité de l'utilisateur de résoudre le problème en demandant conseil au service après-vente du constructeur.



Dans tous les cas, les perturbations électromagnétiques doivent être réduites de manière à ne plus représenter une gêne.



Avant l'installation de l'appareil, l'utilisateur devra évaluer les problèmes électromagnétiques potentiels qui pourraient survenir aux abords de la zone de travail et en particulier sur la santé des personnes situées à proximité (personnes portant un pacemaker ou un appareil auditif).

Blindage

Le blindage sélectif d'autres câbles et appareils présents à proximité de la zone peut réduire les problèmes d'interférences. Le blindage de toute l'installation de soudage (découpage) peut être envisagé pour des applications spéciales.

S 1.5 Degré de protection IP

IP23S

- Boîtier de protection contre l'accès aux parties dangereuses par un doigt et contre des corps solides étrangers ayant un diamètre supérieur/égal à 12.5 mm.
- Grille de protection contre une pluie tombant à 60°.
- Boîtier protégé contre les effets nuisibles dus à la pénétration d'eau lorsque les parties mobiles de l'appareil ne sont pas encore en fonctionnement.

1.6 Liquide de refroidissement

1.6.1 Protection individuelle



Produit nocif par ingestion. Il peut irriter les yeux, les muqueuses et l'épiderme.



Éviter le contact en mettant des gants en caoutchouc.



Éviter les projections accidentelles en mettant des lunettes de protection.



Éviter le contact avec la peau en portant des vêtements de travail appropriés.

1.6.2 Élimination



Toutes fuites ou résidus de produit, après utilisation, doivent être traités dans une usine de purification appropriée. Il convient si possible de recycler le produit. Il est interdit de vider le produit usé dans les cours d'eau, dans les fosses ou les systèmes de drainage. Le fluide dilué ne devrait pas être vidé dans les égouts, sauf si cela est admis par la réglementation locale.

2 INSTALLATION



L'installation ne peut être effectuée que par du personnel expérimenté et agréé par le constructeur.



Pendant l'installation, s'assurer que le générateur est déconnecté du réseau.



2.1 Mode de soulèvement, de transport et de déchargement

- La machine ne dispose d'aucun élément spécifique pour le levage.



Ne pas sous-évaluer le poids de l'installation, se reporter aux caractéristiques techniques.

Ne pas faire passer ou arrêter la charge suspendue au-dessus de personnes ou d'objets.



Ne pas laisser tomber le matériel ou ne pas créer de pression inutile sur l'appareil.



2.2 Installation de l'appareil

Observer les règles suivantes :

- Réserver un accès facile aux commandes et aux connexions de l'appareil.
- Ne pas installer l'appareil dans des locaux de petites dimensions.
- Ne jamais placer la machine sur un plan incliné de plus de 10° par rapport à l'horizontale.
- Installer le matériel dans un endroit sec, propre et avec une aération appropriée.
- Mettre l'installation à l'abri de la pluie battante et ne pas l'exposer aux rayons du soleil.

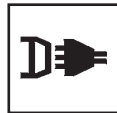

2.3 Branchement et raccordement

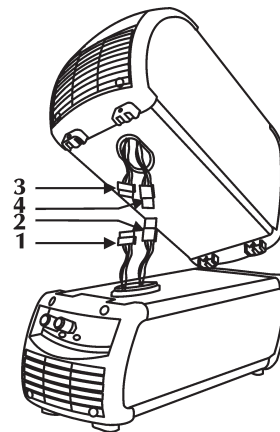

Le groupe de refroidissement est équipé d'un connecteur 1 pour le raccordement au générateur.

Le groupe de refroidissement est équipé d'un connecteur 2 pour le raccordement au générateur.



Déconnecter le générateur du réseau avant toute intervention interne.

- Ouvrir la porte inférieure du générateur en enlevant les deux vis.
- Brancher le connecteur mâle 1 du groupe de refroidissement au connecteur femelle 2 du générateur.
- Brancher le connecteur mâle 3 du groupe de refroidissement au connecteur femelle 4 du générateur.



2.4 Mise en service

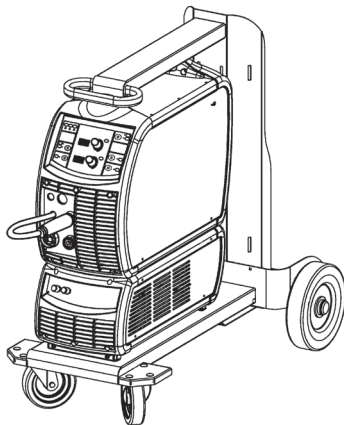



- Installer le WU sur le GT et le fixer grâce à ses 4 vis (1).
- Placer le générateur sur le groupe de refroidissement et le fixer avec les vis correspondantes.

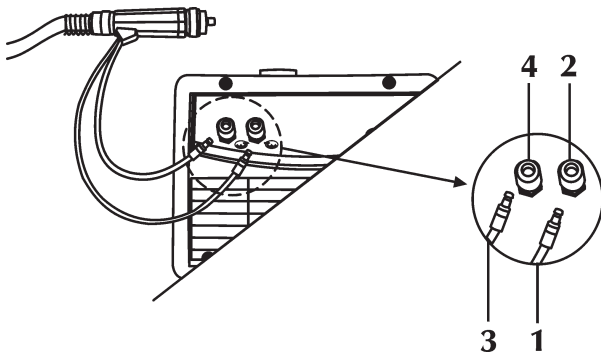

Effectuer les opérations suivantes avant la mise en marche de l'appareil:

- Enlever le bouchon de fermeture du réservoir.
- Enlever le bouchon hermétique du goulot en faisant levier sur le bord du bouchon à l'aide d'un outil.
- Ajouter du liquide dans le réservoir si nécessaire.
- Conserver le bouchon hermétique pour transporter éventuellement le groupe par la suite.



- Connecter le tuyau rouge de la torche (1) au raccord rapide d'entrée approprié (2) (rouge - symbole .
- Relier le tuyau bleu de la torche (3) au raccord rapide de sortie approprié (4) (bleu - symbole .



Toujours monter le tuyau by-pass quand la torche n'est pas branchée aux bornes d'entrée/de sortie du liquide de refroidissement pour ne pas abîmer le groupe de refroidissement.



N'utiliser que du liquide réfrigérant code 18.91.001.

3 PRÉSENTATION DE L'APPAREIL

3.1 Panneau frontal

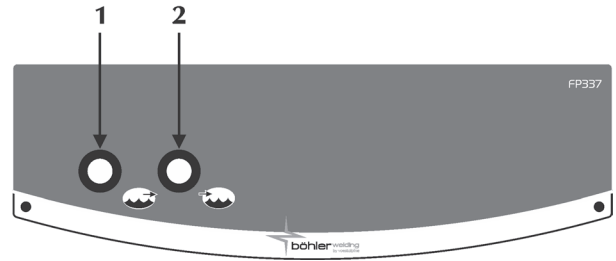

1 Raccord de sortie du liquide réfrigérant



Permet d'introduire du liquide à basse température dans le circuit de refroidissement de la torche.

2 Raccord d'entrée du liquide réfrigérant



Permet de réintroduire le liquide réchauffé par son passage dans la torche dans le circuit de refroidissement interne du WU.

4 ENTRETIEN



Effectuer l'entretien courant de l'installation selon les indications du constructeur.

Toute opération de maintenance doit exclusivement être effectuée par un personnel qualifié.

Toutes les portes d'accès et de service ainsi que les capots doivent être fermés et correctement fixés lorsque la source fonctionne.

Toute modification non autorisée par le fabricant est strictement interdite.

Eviter l'accumulation de poussière métallique à proximité et sur les ailettes d'aération.



Déconnecter le générateur du réseau avant toute intervention !



Contrôler régulièrement le niveau du liquide réfrigérant dans le réservoir. Si le réservoir est complètement vide ou en cas de présence d'air dans la pompe, l'amorçage de cette dernière peut ne pas se produire.

- Contrôler la quantité de liquide dans le réservoir (2/3 d'eau et 1/3 de liquide antigel).
- Effectuer le nettoyage interne avec de l'air comprimé à basse pression et des brosses souples.
- Contrôler les connexions électriques et tous les câbles de branchement.
- Contrôler l'état de la pompe.
- Contrôler si les raccordements des tuyaux sont effectués correctement.

Tous les six mois, vidanger le liquide de refroidissement et rincer les tuyaux et le réservoir avec de l'eau.

Vidanger le liquide s'il bout, car il perdrait ses propriétés protectrices.



Ne remplir le réservoir de liquide réfrigérant que lorsque le générateur et le groupe WU sont assemblés et posés sur un plan horizontal.



N'utiliser que du liquide réfrigérant code 18.91.001.

Ne jamais utiliser l'équipement sans liquide réfrigérant.



Ne pas utiliser de liquides réfrigérants conducteurs.

Le non-respect de cet entretien régulier entraînera l'annulation de la garantie et déchargera le constructeur de toute responsabilité.

5 INCIDENTS



La réparation ou le remplacement de pièces sur l'installation doivent exclusivement être effectués par un personnel technique qualifié.

La réparation ou le remplacement de pièces sur l'installation effectués par un personnel non autorisé implique l'annulation immédiate de la garantie du produit.

L'installation ne doit être soumise à aucun type de modification.

Le constructeur décline toute responsabilité si l'opérateur ne respecte pas ces instructions.

Pas de débit d'eau dans le circuit

Cause Manque de liquide dans le réservoir.

Solution Ajouter du liquide.

Cause Air dans le circuit de refroidissement.

Solution Connecter le faisceau eau raccord rapide à la connexion de sortie  (bleue) et purger le système hydraulique pour permettre au liquide de refroidissement de s'échapper pendant quelques secondes.

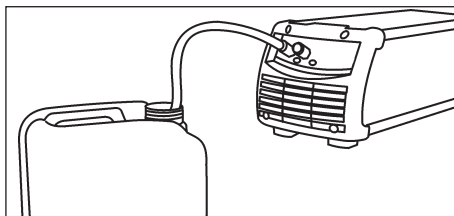

Cause Circuit de refroidissement bloqué ou défectueux.

Solution Vérifier l'état des connexions du circuit hydraulique (à l'intérieur de l'appareil).

Vérifier l'état du circuit hydraulique de la torche.

Vérifier l'état du circuit de refroidissement dans le faisceau.

S'adresser service après-vente le plus proche pour la réparation de l'installation.

Cause Présence de l'alarme du refroidisseur.

Solution Réinitialiser l'alarme.

Connecter une torche ou le faisceau eau raccord rapide aux modes d'opération nécessitant un refroidisseur actif.

Vérifier l'état des connexions du circuit hydraulique (à l'intérieur de l'appareil).

Vérifier l'état du circuit hydraulique de la torche.

S'adresser service après-vente le plus proche pour la réparation de l'installation.

Cause Pompe défectueuse.

Solution Remplacer le composant endommagé.

S'adresser service après-vente le plus proche pour la réparation de l'installation.

Capacité de refroidissement insuffisante

Cause Ventilateur défectueux.

Solution Remplacer le composant endommagé.

S'adresser service après-vente le plus proche pour la réparation de l'installation.

Cause Pompe défectueuse.

Solution Remplacer le composant endommagé.

S'adresser service après-vente le plus proche pour la réparation de l'installation.

6 CARACTÉRISTIQUES TECHNIQUES

WU 330	
Tension d'alimentation U1	1x400 V
Courant absorbé I1max	0.5 A
Puissance de refroidissement (25°C)	1.0 Kw
Type d'échangeur	H2O - Air
Débit nominal (QV)	2.3 l/min
Débit maximal (Qvmax)	4.6 l/min
Hauteur d'élévation pompe (Hmax)	35 m
Type de pompe	Rotative
Nombre maximal de tours	2900 tours/min
Degré de protection IP	IP23S
Capacité du réservoir	5.5 l
Dimensions (LxPxH)	705x305x250 mm
Poids	15.0 Kg.
Normes de construction	EN 60974-2/EN 60974-10

DECLARACIÓN DE CONFORMIDAD CE

La empresa

SELCO s.r.l. - Via Palladio, 19 - 35019 ONARA DI TOMBOLO (Padova) - ITALY

Tel. +39 049 9413111 - Fax +39 049 9413311 - E-mail: selco@selcoweld.com - www.selcoweld.com

declara que el aparato tipo

WU 330

es conforme a las directivas EU:

2014/35/EU

LOW VOLTAGE DIRECTIVE

2014/30/EU

EMC DIRECTIVE

2011/65/EU

RoHS DIRECTIVE

que se han aplicado las normas:

EN 60974-2:2014

EN 60974-10:2015 Class A

Toda reparación, o modificación, no autorizada por **SELCO s.r.l.** hará decaer la validez e invalidará esta declaración.

Onara di Tombolo (PADOVA)

Selco s.r.l.



Lino Frasson
Chief Executive

INDICE

1 ADVERTENCIA	29
1.1 Entorno de utilización.....	29
1.2 Protección personal y de terceros	29
1.3 Protección contra descargaseléctricas.....	29
1.4 Campos electromagnéticos e interferencias.....	29
1.5 Grado de protección IP	30
1.6 Líquido de refrigeración.....	30
1.6.1 Protección personal	30
1.6.2 Desecho	30
2 INSTALACIÓN.....	30
2.1 Modo de levantamiento, transporte y descarga.....	30
2.2 Colocación del equipo.....	30
2.3 Conexión.....	30
2.4 Puesta en servicio	31
3 PRESENTACIÓN DEL EQUIPO.....	31
3.1 Panel frontal	31
4 MANTENIMIENTO	31
5 DIAGNÓSTICO Y SOLUCIONES.....	32
6 CARACTERÍSTICAS TÉCNICAS	32

SÍMBOLOS



Peligros inminentes que causan lesiones graves y comportamientos peligrosos que podrían causar lesiones graves



Comportamientos que podrían causar lesiones no leves, o daños a las cosas



Las notas anteceditas precedidas de este símbolo son de carácter técnico y facilitan las operaciones

1 ADVERTENCIA



Antes de comenzar cualquier tipo de operación, tiene que haber comprendido el contenido del presente manual.

No efectúe modificaciones ni mantenimientos no descritos en este manual.

El fabricante no es responsable por daños a personas o cosas causados por una lectura, o una puesta en aplicación negligente de cuanto escrito del contenido de este manual.



En caso de dudas o problemas sobre la utilización del equipo, no se indiquen aquí, consulte con personal cualificado.



1.1 Entorno de utilización

- El equipo debe utilizarse exclusivamente para las operaciones para las cuales ha sido diseñado, en los modos y dentro de los campos previstos en la placa de identificación y/o en este manual, según las directivas nacionales e internacionales sobre la seguridad. Un uso diferente del declarado por el fabricante se considera inadecuado y peligroso; en dicho caso, el fabricante no asumirá ninguna responsabilidad.
- Este equipo tiene que debe utilizarse sólo para fines profesionales en un local industrial.
El fabricante no responde de daños provocados por un uso del equipo en entornos domésticos.
- El equipo debe utilizarse en locales con una temperatura comprendida entre -10°C y $+40^{\circ}\text{C}$ (entre $+14^{\circ}\text{F}$ y $+104^{\circ}\text{F}$).
El equipo debe transportarse y almacenarse en locales con una temperatura comprendida entre -25°C y $+55^{\circ}\text{C}$ (entre -13°F y 131°F).
- El equipo debe utilizarse en locales sin polvo, ácidos, gases ni otras sustancias corrosivas.
- El equipo debe utilizarse en locales con una humedad relativa no superior al 50% a 40°C (104°F).
El equipo debe utilizarse en locales con una humedad relativa no superior al 90% a 20°C (68°F).
- El equipo debe utilizarse a una altitud máxima sobre el nivel del mar de 2000 m (6500 pies).

1.2 Protección personal y de terceros



Compruebe que el grupo de refrigeración esté apagado antes de desconectar los tubos de suministro y de retorno del líquido refrigerante. El líquido caliente que sale podría provocar graves quemaduras.



Tenga a mano un equipo de primeros auxilios. No subestime quemaduras o heridas.



Antes de abandonar el puesto de trabajo, tome todas las medidas de seguridad para dejar la zona de trabajo segura y así impedir accidentes graves a personas o bienes.



1.3 Protección contra descargas eléctricas

- Las descargas eléctricas suponen un peligro de muerte.
- No toque las piezas internas ni externas bajo tensión del equipo de soldadura/corte mientras el equipo éste se encuentre activado (antorchas, pinzas, cables de masa, electrodos, alambres, rodillos y bobinas están conectados eléctricamente al circuito de soldadura).
- Compruebe el aislamiento eléctrico del equipo y del soldador, utilizando superficies y bases secas y aisladas perfectamente del potencia de tierra y de masa de la tierra.



1.4 Campos electromagnéticos e interferencias

Clasificación EMC de dispositivos de acuerdo con la Normativa EN/IEC 60974-10 (Consulte la tarjeta de datos o las características técnicas)

Los dispositivos de clase B cumplen con los requisitos de compatibilidad electromagnética en entornos industriales y residenciales, incluyendo las áreas residenciales en las que la energía eléctrica se suministra desde un sistema público de baja tensión.

Los dispositivos de clase A no están destinados al uso en áreas residenciales en las que la energía eléctrica se suministra desde un sistema público de baja tensión. Puede ser potencialmente difícil asegurar la compatibilidad electromagnética de los dispositivos de clase A en estas áreas, a causa de las perturbaciones irradiadas y conducidas.

Instalación, uso y evaluación del área

Este equipo responde a las indicaciones contenidas en la norma armonizada EN60974-10 y está identificado como de "CLASE A". Este equipo tiene que debe utilizarse sólo para fines profesionales en un local industrial.

El fabricante no responde de daños provocados por un uso del equipo en entornos domésticos.



El usuario debe ser un experto del sector y como tal es responsable de la instalación y del uso del aparato según las indicaciones del fabricante.

Si se detectasen perturbaciones electromagnéticas, el usuario del equipo tendrá que resolver la situación sirviéndose de la asistencia técnica del fabricante.



Debe procurar reducir las perturbaciones electromagnéticas hasta un nivel que no resulte molesto.



Antes de instalar este equipo, el usuario tiene que evaluar los potenciales problemas electro-magnéticos que podrían producirse en la zona circundante y, en particular, la salud de las personas expuestas, por ejemplo: personas con marcapasos y aparatos acústicos.

Blindaje

El blindaje selectivo de otros cables y aparatos presentes en la zona circundante puede reducir los problemas de interferencia. El blindaje de todo el equipo de soldadura (corte) puede tomarse en consideración para aplicaciones especiales.



1.5 Grado de protección IP

IP23S

- Para evitar el contacto de los dedos con partes peligrosas y la entrada de cuerpos sólidos extraños de diámetro mayor/igual a 12.5 mm.
- Envoltura protegida contra la lluvia a 60° sobre la vertical.
- Envoltura protegida contra los efectos dañinos debidos a la entrada de agua, cuando las partes móviles del aparato no están en movimiento.



1.6 Líquido de refrigeración

1.6.1 Protección personal



Producto nocivo por ingestión. Puede provocar irritación en los ojos, las mucosas y la piel.



Evite el contacto utilizando guantes de goma.



Evite las salpicaduras accidentales utilizando gafas de seguridad.



Evite el contacto con la piel utilizando vestimenta laboral.

1.6.2 Desecho



Las pérdidas o los residuos del producto, después de haberlo empleado para su utilización habitual, deben ser tratados en una instalación de depuración adecuada o, a ser posible, debe reciclarse el producto. No está permitido desechar el producto usado en cursos de agua, pozos o sistemas de desagüe. El fluido diluido no debe vaciarse en las alcantarillas, salvo en los casos en que esté permitido por las normativas locales.

2 INSTALACIÓN



La instalación debe efectuarla solamente personal experto y habilitado por el fabricante.



Durante la instalación compruebe que el generador esté desconectado de la red de alimentación.



2.1 Modo de levantamiento, transporte y descarga

- El equipo no incorpora elementos específicos para el levantamiento.



No subestime el peso del equipo, consulte las características técnicas.

No traslade ni detenga la carga encima de personas u objetos.



No aplique una presión excesiva sobre el equipo.



2.2 Colocación del equipo

Observe las siguientes normas:

- El acceso a los mandos y conexiones tiene que ser fácil.
- No coloque el equipo en lugares estrechos.
- No coloque nunca el equipo sobre una superficie con una inclinación superior a 10° respecto del plano horizontal.
- Colocar el equipo en un lugar seco, limpio y con ventilación apropiada.
- Proteja la instalación de la lluvia y del sol.

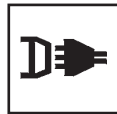

2.3 Conexión

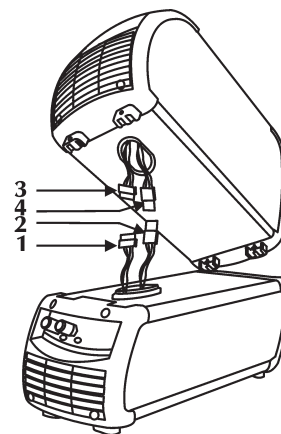

El grupo de refrigeración está dotado de un conector 1 para la conexión a la fuente de alimentación.

El grupo de refrigeración está dotado de un conector 2 para la conexión a la fuente de alimentación.



¡Antes de cada operación, corte la alimentación desconecte el equipo!

- Abra la tapa de la parte inferior de la fuente de alimentación quitando los dos tornillos.
- Conecte el conector macho 1 del grupo de refrigeración al conector hembra 2 de la fuente de alimentación.
- Conecte el conector macho 3 del grupo de refrigeración al conector hembra 4 de la fuente de alimentación.



2.4 Puesta en servicio

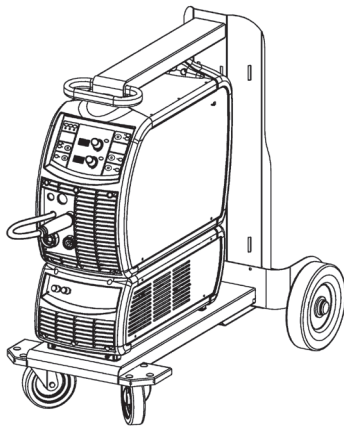



- Coloque WU sobre GT y fíjelo con los 4 tornillos (1) respectivos.
- Coloque la fuente de alimentación encima del grupo de refrigeración y fíjelo con los tornillos respectivos.

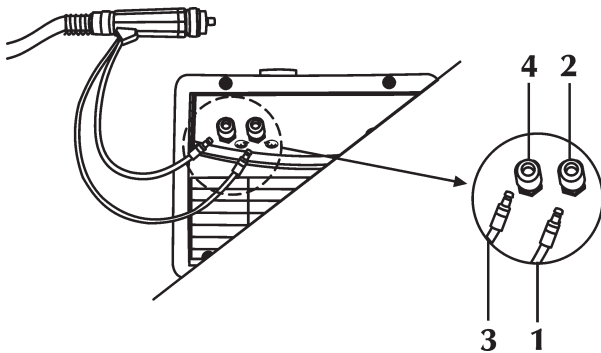

Antes de poner en funcionamiento el grupo realice las siguientes operaciones:

- Retire el tapón de cierre del tanque.
- Retire el tapón hermético del canal de entrada, haciendo palanca con un utensilio en el borde del tapón.
- Si es necesario, añada refrigerante dentro al tanque.
- Guarde el tapón hermético para eventuales transportes futuros del grupo.



- Conecte el tubo de retorno del líquido refrigerante de la antorcha (1) (color rojo) al racor/conexión correspondiente (2) (color rojo - símbolo )
- Conecte el tubo de alimentación del líquido refrigerante de la antorcha (3) (color azul) al racor/conexión correspondiente (4) (color azul - símbolo )



Para no dañar el grupo de refrigeración, conecte siempre el tubo by-pass cuando la antorcha no esté conectada a los terminales de entrada/salida del líquido refrigerante.



Para llenar el depósito utilice líquido refrigerante cód. 18.91.001.

3 PRESENTACIÓN DEL EQUIPO

3.1 Panel frontal

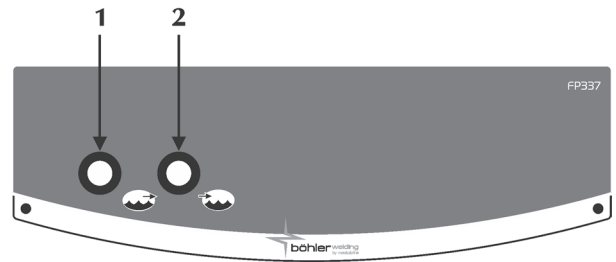

1 Racor de salida del líquido refrigerante



Permite introducir líquido a baja temperatura en el circuito de refrigeración de la antorcha.

2 Racor de entrada del líquido refrigerante



Permite introducir el líquido, calentado por la antorcha, en el circuito de refrigeración interior del WU.

4 MANTENIMIENTO



Efectúe el mantenimiento ordinario del equipo según las indicaciones del fabricante.

El mantenimiento tiene que ser efectuado exclusivamente por personal cualificado.

Cuando el aparato esté funcionando, todas las puertas de acceso y de servicio y las tapas tienen que estar cerradas y fijadas perfectamente.

El equipo no debe modificarse.

Procure que no se forme polvo metálico en proximidad y cerca o encima de las aletas de ventilación.



¡Antes de cada operación, corte la alimentación desconecte el equipo!



Periódicamente, controle el nivel del líquido refrigerante en el depósito. Si el depósito quedara completamente vacío, o si entrara aire en la bomba, la misma ésta podría no arrancar.

- Controle la cantidad de líquido en el depósito (2/3 de agua y 1/3 de líquido anticongelante).
- Limpie el interior con aire comprimido a baja presión y con pinceles de cerdas suaves.
- Controle las conexiones eléctricas y todos los cables de conexión.
- Controle el estado de la electrobomba.
- Controle el estado de las conexiones de los tubos.

Cada seis meses, cambie el líquido refrigerante y enjuague los tubos y el tanque con agua. Cambie el líquido si hierve, porque perdería sus propiedades metálicas de protección.



El llenado del depósito con líquido refrigerante se debe realizar con la fuente de alimentación y WU montados y colocados sobre una superficie horizontal.



Para llenar el depósito utilice líquido refrigerante cód. 18.91.001.

Se prohíbe utilizar el equipo sin el líquido refrigerante.



No utilice líquidos refrigerantes conductivos.

La carencia de este mantenimiento, invalidará todas las garantías y eximirá al fabricante de toda responsabilidad.

5 DIAGNÓSTICO Y SOLUCIONES



La reparación o sustitución de componentes del equipo debe realizarla personal técnico cualificado.

La reparación o la sustitución de componentes del equipo por parte de personal no autorizado provoca la caducidad inmediata de la garantía del producto.

No debe hacerse ningún tipo de modificación en el equipo.

Si el operador no respetara las instrucciones descritas, el fabricante declina cualquier responsabilidad.

Falta de flujo en el circuito

Causa Falta de líquido en el depósito.

Solución Rellene el depósito.

Causa Aire en el circuito de refrigeración.

Solución Inserte el bypass en la unión de salida  (color azul) y ventile el circuito hidráulico permitiendo la salida del líquido refrigerante durante algunos segundos.

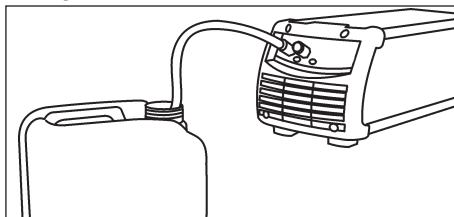

Causa Circuito de refrigeración atascado o interrumpido.

Solución Compruebe el estado de las conexiones (internas al grupo) del circuito hidráulico.
Compruebe el estado del circuito hidráulico de la antorcha.
Compruebe el estado del circuito hidráulico del conjunto de cables.
Contacte con el centro de asistencia más cercano para la reparación del equipo.

Causa Presencia de la alarma del grupo de refrigeración.

Solución Reiniciar la alarma.
Conecte una antorcha o el bypass en los modos de funcionamiento que prevén el grupo de refrigeración en actividad.

Compruebe el estado de las conexiones (internas al grupo) del circuito hidráulico.

Compruebe el estado del circuito hidráulico de la antorcha.

Contacte con el centro de asistencia más cercano para la reparación del equipo.

Causa Bomba averiada.

Solución Sustituya el componente averiado.

Contacte con el centro de asistencia más cercano para la reparación del sistema.

Capacidad insuficiente de refrigeración

Causa Ventilador averiado.

Solución Sustituya el componente averiado.

Contacte con el centro de asistencia más cercano para la reparación del sistema.

Causa Bomba averiada.

Solución Sustituya el componente averiado.

Contacte con el centro de asistencia más cercano para la reparación del sistema.

6 CARACTERÍSTICAS TÉCNICAS

WU 330	
Tensión de alimentación U1	1x400 V
Corriente absorbida I1 max	0.5 A
Potencia de refrigeración (25°C)	1.0 Kw
Tipo de intercambiador	H2O - Aire
Capacidad nominal (QV)	2.3 l/min
Capacidad máxima (Qvmax)	4.6 l/min
Altura de elevación bomba (Hmax)	35 m
Tipo de bomba	Centrífuga
Nº de revoluciones máximo	2900 min
Clase de protección IP	IP23S
Capacidad del depósito	5.5 l
Dimensiones (l x p x h)	705x305x250 mm
Peso	15.0 Kg.
Normas de fabricación	EN 60974-2/EN 60974-10

DECLARAÇÃO DE CONFORMIDADE CE

A empresa
SELCO s.r.l. - Via Palladio, 19 - 35019 ONARA DI TOMBOLO (Padova) - ITALY
Tel. +39 049 9413111 - Fax +39 049 9413311 - E-mail: selco@selcoweld.com - www.selcoweld.com

declara que o aparelho tipo **WU 330**

está conforme às directivas UE: **2014/35/EU LOW VOLTAGE DIRECTIVE**
2014/30/EU EMC DIRECTIVE
2011/65/EU RoHS DIRECTIVE

e que foram aplicadas as normas: **EN 60974-2:2014**
EN 60974-10:2015 Class A

Cada intervenção ou modificação não autorizada pela **SELCO s.r.l.** anulará a validade desta declaração.

Onara di Tombolo (PADOVA)

Selco s.r.l.



Lino Frasson
Chief Executive

ÍNDICE GERAL

1 ATENÇÃO	35
1.1 Condições de utilização	35
1.2 Protecção do operador e de outros indivíduos.....	35
1.3 Protecção contra choques eléctricos	35
1.4 Campos electromagnéticos e interferências.....	35
1.5 Grau de protecção IP.....	36
1.6 Líquido de refrigeração	36
1.6.1 Protecção pessoal	36
1.6.2 Eliminação	36
2 INSTALAÇÃO	36
2.1 Elevação, transporte e descarga	36
2.2 Posicionamento do equipamento.....	36
2.3 Ligações	36
2.4 Instalação.....	37
3 APRESENTAÇÃO DO SISTEMA	37
3.1 Painel frontal	37
4 MANUTENÇÃO	37
5 RESOLUÇÃO DE PROBLEMAS.....	38
6 CARACTERÍSTICAS TÉCNICAS	38

SIMBOLOS



Perigo iminente de lesões corporais graves e de comportamentos perigosos que podem provocar lesões corporais graves



Informação importante a seguir de modo a evitar lesões menos graves ou danos em bens



Todas as notas precedidas deste símbolo são sobretudo de carácter técnico e facilitam as operações

1 ATENÇÃO



Antes de iniciar qualquer tipo de operação na máquina, é necessário ler cuidadosamente e compreender o conteúdo deste manual. Não efectuar modificações ou operações de manutenção que não estejam previstas.

O fabricante não se responsabiliza por danos causados em pessoas ou bens, resultantes da utilização incorrecta ou da não-aplicação do conteúdo deste manual.



Para quaisquer dúvidas ou problemas relativos à utilização do equipamento, ainda que não se encontrem aqui descritos, consultar pessoal qualificado.



1.1 Condições de utilização

- Cada instalação deve ser utilizada exclusivamente para as operações para que foi projectada, nos modos e nos âmbitos previstos na chapa de características e/ou neste manual, de acordo com as directivas nacionais e internacionais relativas à segurança. Uma utilização diferente da expressamente declarada pelo construtor deve ser considerada completamente inadequada e perigosa e, neste caso, o construtor declina toda e qualquer responsabilidade.
- Esta unidade deverá ser utilizada apenas com fins profissionais, numa instalação industrial.
O construtor declina qualquer responsabilidade por eventuais danos provocados pela utilização da instalação em ambientes domésticos.
- O equipamento deve ser utilizado em ambientes cujas temperaturas estejam compreendidas entre -10°C e +40°C (entre +14°F e +104°F).
O equipamento deve ser transportado e armazenado em ambientes cujas temperaturas estejam compreendidas entre -25°C e +55°C (entre -13°F e 131°F).
- O equipamento deve ser utilizado em ambientes sem poeira, ácidos, gases ou outras substâncias corrosivas.
- O equipamento deve ser utilizado em ambientes com humidade relativa não superior a 50% a 40°C (104°F).
O equipamento deve ser utilizado em ambientes com humidade relativa não superior a 90% a 20°C (68°F).
- O equipamento deve ser utilizado a uma altitude máxima sobre o nível do mar de 2000 m (6500 pés).

1.2 Protecção do operador e de outros indivíduos



Assegurar que o grupo de refrigeração é desactivado, antes de desligar os tubos de alimentação e retorno do líquido de refrigeração. O líquido quente em saída pode provocar queimaduras graves.



Manter perto de si um estojo de primeiros socorros, pronto a utilizar.
Não subestimar qualquer queimadura ou ferida.



Antes de abandonar o posto de trabalho, deixar a área de trabalho em boas condições de segurança, de maneira a evitar danos materiais e pessoais acidentais.



1.3 Protecção contra choques eléctricos

- Um choque de descarga eléctrica pode ser mortal.
- Evitar tocar nas zonas normalmente sob tensão, no interior ou no exterior da máquina de soldar/corte, enquanto a própria instalação estiver alimentada (tochas, pistolas, cabos de terra, fios, rolos e bobinas estão electricamente ligados ao circuito de soldadura).
- Efectuar o isolamento eléctrico da instalação e do operador de soldadura, utilizando planos e bases secos e suficientemente isolados da terra.



1.4 Campos electromagnéticos e interferências

Classificação do equipamento (CEM), em conformidade com a norma EN/IEC 60974-10 (Consultar a placa sinalética ou os dados técnicos)

O equipamento Classe B cumpre os requisitos de compatibilidade electromagnética em ambientes industriais e residenciais, incluindo zonas residenciais em que o fornecimento de energia eléctrica é efectuado pela rede pública de baixa tensão.

O equipamento Classe A não deve ser utilizado em zonas residenciais em que o fornecimento de energia eléctrica é efectuado pela rede pública de baixa tensão, dado que eventuais perturbações de condutividade e radiação poderão dificultar a compatibilidade electromagnética do equipamento classe A nessas zonas.

Instalação, utilização e estudo da área

Este equipamento foi construído em conformidade com as indicações contidas na norma harmonizada EN60974-10 e está identificado como da "CLASSE A".

Esta unidade deverá ser apenas utilizada com fins profissionais, numa instalação industrial.

O construtor declina qualquer responsabilidade por eventuais danos provocados pela utilização da instalação em ambientes domésticos.



O utilizador tem de ser um especialista na actividade e, como tal, é responsável pela instalação e pela utilização do equipamento, segundo as indicações do fabricante. Caso se detectem perturbações electromagnéticas, o operador do equipamento terá de resolver o problema, se necessário com a assistência técnica do fabricante.



As perturbações electromagnéticas têm sempre que ser reduzidas até deixarem de constituir um problema.



Antes de instalar este equipamento, o utilizador deverá avaliar potenciais problemas electromagnéticos que poderão ocorrer nas zonas circundantes e, particularmente, os relativos às condições de saúde das pessoas expostas, por exemplo, das pessoas que possuem "pacemakers" ou aparelhos auditivos.

Blindagem

A blindagem selectiva de outros cabos e equipamentos presentes na zona circundante, pode reduzir os problemas provocados por interferência electromagnética. A blindagem de toda a instalação de soldadura (corte) pode ser considerada para aplicações especiais.



1.5 Grau de protecção IP

IP23S

- Invólucro protegido contra o acesso de dedos a partes perigosas e contra objectos sólidos com diâmetro superior/ igual a 12,5 mm.
- Invólucro protegido contra chuva que caia num ângulo até.
- Invólucro protegido contra os efeitos danosos devidos à entrada de água, quando as partes móveis do equipamento não estão em movimento.



1.6 Líquido de refrigeração

1.6.1 Protecção pessoal



Produto nocivo por ingestão. Pode provocar irritação nos olhos, nas mucosas e na pele.



Evitar o contacto utilizando luvas de borracha.



Evitar os salpicos acidentais utilizando óculos de segurança.



Evitar o contacto com a pele utilizando vestuário de trabalho normal.

1.6.2 Eliminação



Após utilização, as perdas ou resíduos do produto devem ser processados numa instalação de tratamento adequada ou, se possível, o produto deverá ser reciclado. Não é permitido despejar o produto em cursos de água, fossas ou sistemas de drenagem.

O fluido diluído não deve ser despejado na rede de esgotos, excepto se tal for permitido pela legislação local.

2 INSTALAÇÃO



A instalação só pode ser executada por pessoal experiente e autorizado pelo fabricante.



Para executar a instalação, assegurar-se de que o gerador está desligado da rede de alimentação.



2.1 Elevação, transporte e descarga

- O equipamento não está equipado com elementos específicos para a elevação.



Nunca subestimar o peso do equipamento, (ver características técnicas).



Nunca deslocar, ou posicionar, a carga suspensa sobre pessoas ou bens.



Não deixar cair o equipamento ou a unidade, nem os pousar com força no chão.



2.2 Posicionamento do equipamento

Observar as seguintes regras:

- Fácil acesso aos comandos e ligações do equipamento.
- Não colocar o equipamento em espaços reduzidos.
- Nunca colocar o equipamento num plano com inclinação superior a 10° em relação ao plano horizontal.
- Ligar o equipamento num lugar seco, limpo e com ventilação apropriada.
- Proteger o equipamento da chuva e do sol.

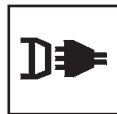

2.3 Ligações

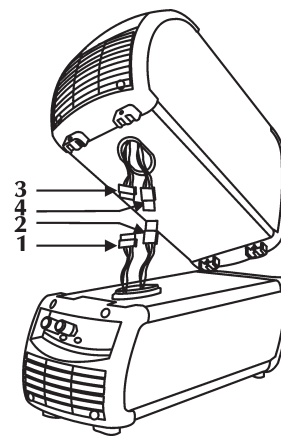

O grupo de refrigeração está equipado com um conector 1 para ligação ao gerador.

O grupo de refrigeração está equipado com um conector 2 para ligação ao gerador.



Desligar a instalação antes de cada operação!

- Abrir a tampa na capota inferior do gerador retirando os dois parafusos.
- Ligar o conector macho 1 do grupo de refrigeração ao conector fêmea 2 do gerador.
- Ligar o conector macho 3 do grupo de refrigeração ao conector fêmea 4 do gerador.



2.4 Instalação

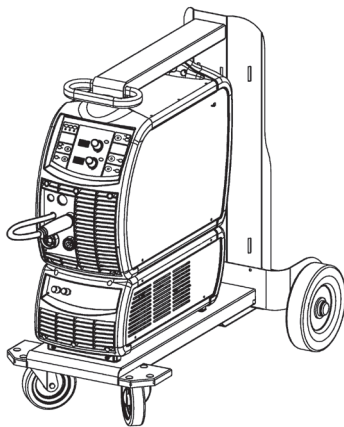



- Apoiar o WU sobre o GT e fixá-lo com os 4 parafusos (1).
- Colocar o gerador sobre o grupo de refrigeração e fixá-lo com os parafusos previstos para o efeito.

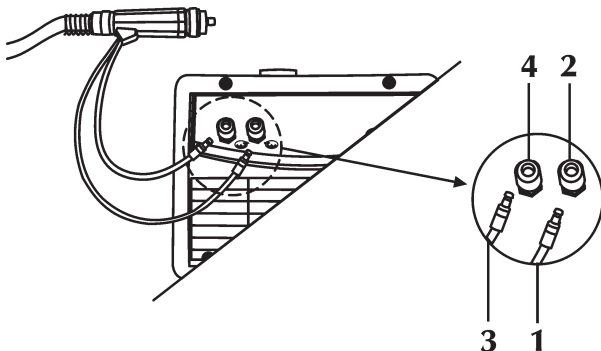

Antes de pôr o grupo em funcionamento, executar as seguintes operações:

- Retirar a tampa do reservatório.
- Retirar a tampa hermética do bocal, fazendo alavanca com uma ferramenta apoiada no bordo da tampa.
- Se necessário, acrescentar líquido ao reservatório.
- Conservar a tampa hermética, para futuras utilizações no transporte do grupo.



- Ligar o tubo de retorno da tocha (1) (vermelho) ao conector rápido específico (2) (vermelho - símbolo ).
- Ligar o tubo de alimentação da tocha (3) (azul escuro) ao conector rápido específico (4) (azul escuro - símbolo ).



Para não danificar a unidade de refrigeração, montar sempre o tubo by-pass quando a tocha não está ligada aos terminais de entrada/saída do líquido de refrigeração.



O reservatório deve ser cheio com líquido de refrigeração cód. 18.91.001.

3 APRESENTAÇÃO DO SISTEMA

3.1 Painel frontal

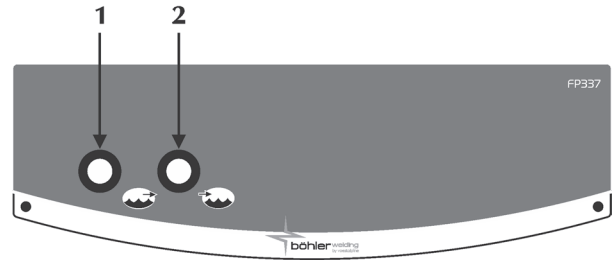

1 Ligação de saída do líquido de refrigeração



Permite introduzir o líquido a baixa temperatura no circuito de refrigeração da tocha.

2 Ligação de entrada do líquido de refrigeração



Permite introduzir líquido, sujeito ao aquecimento da tocha, no circuito de refrigeração interno da WU.

4 MANUTENÇÃO



A instalação deve ser submetida a operações de manutenção de rotina, de acordo com as indicações do fabricante.

As operações de manutenção deverão ser efectuadas exclusivamente por pessoal especializado.

Quando o equipamento está em funcionamento, todas as portas e tampas de acesso e de serviço deverão estar fechadas e trancadas.

São rigorosamente proibidas quaisquer alterações não-autorizadas do sistema.

Evitar a acumulação de poeiras condutoras de electricidade perto das aletas de ventilação e sobre as mesmas.



Antes da qualquer operação de manutenção desligar o equipamento da corrente eléctrica!



Verificar periodicamente o nível do líquido de refrigeração no reservatório. O esvaziamento total do reservatório e/ou a presença de ar na bomba, podem provocar anomalias de funcionamento.

- Verificar a quantidade de líquido no reservatório (2/3 de água 1/3 de líquido anticongelante).
- Limpar o interior do gerador com ar comprimido a baixa pressão e com escovas de cerdas suaves.
- Verificar as ligações eléctricas e todos os cabos de ligação.
- Verificar o estado as condições da electrobomba.
- Verificar o estado das ligações dos tubos.

A cada seis meses, mudar o líquido de refrigeração e lavar os tubos e o reservatório com água. Caso ferva, mudar o líquido, pois poderia perder as propriedades metálicas de protecção.



O enchimento do reservatório com líquido refrigerante deve ser executado com gerador e WU montados e colocados num plano horizontal.



O reservatório deve ser cheio com líquido de refrigeração cód. 18.91.001.

O equipamento não deve ser utilizado sem líquido de refrigeração.



Não utilizar líquidos de refrigeração condutivos.

Caso a referida manutenção não seja executada, todas as garantias serão anuladas, isentando o fabricante de toda e qualquer responsabilidade.

5 RESOLUÇÃO DE PROBLEMAS



A eventual reparação ou substituição de componentes do sistema tem de ser executada exclusivamente por pessoal técnico qualificado.

A reparação ou substituição de componentes do sistema que seja executada por pessoal não-autorizado implica a imediata anulação da garantia do produto.

O sistema não deve ser submetido a nenhum tipo de modificação.

O incumprimento destas instruções isentará o fabricante de toda e qualquer responsabilidade.

Ausência de fluxo no circuito

Causa Ausência de líquido no reservatório.

Solução Efectuar o enchimento.

Causa Ar no circuito de refrigeração.

Solução Aplicar o by-pass na ligação de saída  (cor azul) e purgar o circuito hidráulico, deixando sair o líquido de refrigeração durante alguns segundos.

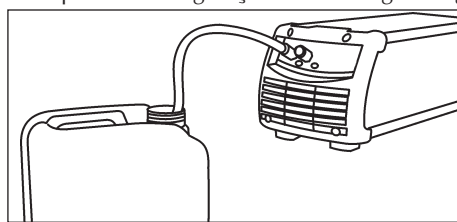

Causa Circuito de refrigeração bloqueado ou avariado.

Solução Verificar o estado das ligações (no interior da unidade) do circuito hidráulico.

Verificar o estado do circuito hidráulico da tocha.

Verificar o estado do circuito de refrigeração no feixe de cabos.

Contactar o centro de assistência mais próximo para a reparação do sistema.

Causa Presença do sinal de alarme da unidade de refrigeração.

Solução Repor o alarme no estado original.

Ligar uma tocha ou o by-pass nos modos de funcionamento que requeiram a activação da unidade de refrigeração.

Verificar o estado das ligações (no interior da unidade) do circuito hidráulico.

Verificar o estado do circuito hidráulico da tocha.

Contactar o centro de assistência mais próximo para a reparação do sistema.

Causa Anomalia na bomba.

Solução Substituir o componente danificado.

Contactar o centro de assistência mais próximo para a reparação do sistema.

Capacidade de refrigeração insuficiente

Causa Anomalia na ventoinha.

Solução Substituir o componente danificado.

Contactar o centro de assistência mais próximo para a reparação do sistema.

Causa Anomalia na bomba.

Solução Substituir o componente danificado.

Contactar o centro de assistência mais próximo para a reparação do sistema.

6 CARACTERÍSTICAS TÉCNICAS

	WU 330
Tensão de alimentação U1	1x400 V
Corrente de entrada I1 max	0.5 A
Potência de refrigeração (25°C)	1.0 Kw
Tipo de permutador	H2O - Ar
Caudal nominal (QV)	2.3 l/min
Caudal máximo (Qvmax)	4.6 l/min
Altura de elevação bomba (Hmax)	35 m
Tipo de bomba	Rotativa
Nº rotações máximo	2900 rotações/min
Grau de protecção IP	IP23S
Capacidade do reservatório	5.5 l
Dimensões (lxpxh)	705x305x250 mm
Peso	15.0 Kg.
Normas de construção	EN 60974-2/EN 60974-10

GELIJKVORMIGHEIDS VERKLARING CE

De firma
SELCO s.r.l. - Via Palladio, 19 - 35019 ONARA DI TOMBOLO (Padova) - ITALY
Tel. +39 049 9413111 - Fax +39 049 9413311 - E-mail: selco@selcoweld.com - www.selcoweld.com

Verklaart dat het apparaat type **WU 330**
conform is met de normen EU: **2014/35/EU LOW VOLTAGE DIRECTIVE**
2014/30/EU EMC DIRECTIVE
2011/65/EU RoHS DIRECTIVE
en dat de volgende normen werden toegepast: **EN 60974-2:2014**
EN 60974-10:2015 Class A

Iedere ingreep of modificatie die niet vooraf door **SELCO s.r.l.** is goedgekeurd maakt dit certificaat ongeldig.

Onara di Tombolo (PADOVA)

Selco s.r.l.



Lino Frasson
Directeur

INHOUDSOPGAVE

1 WAARSCHUWING.....	41
1.1 Gebruiksomgeving	41
1.2 Bescherming voor de lasser en anderen	41
1.3 Beveiliging tegen elektrische schokken.....	41
1.4 Elektromagnetische velden en storingen.....	41
1.5 IP Beveiligingsvermogen.....	42
1.6 Koelvloeistof	42
1.6.1 Persoonlijke bescherming.....	42
1.6.2 Afval	42
2 INSTALLATIE	42
2.1 Procedure voor het optillen, vervoeren en uitladen	42
2.2 Plaatsen van de installatie	42
2.3 Aansluiting.....	42
2.4 Installatie	43
3 PRESENTATIE VAN INSTALLATIE	43
3.1 Voor paneel.....	43
4 ONDERHOUD.....	43
5 DIAGNOSE EN OPLOSSINGEN.....	44
6 TECHNISCHE KENMERKEN	44

SYMBOLEN



Ernstig gevaar op zware verwondingen en waarbij onvoorzichtig gedrag zwaar letsel kan veroorzaken



Belangrijke aanwijzingen die moeten opgevolgd worden om lichte persoonlijke letsels en beschadigingen aan voorwerpen te vermijden



De opmerkingen die na dit symbool komen zijn van technische aard en ergemakkelijken de bewerkingen

1 WAARSCHUWING



Voor het gebruik van de machine dient u zich ervan te overtuigen dat u de handleiding goed heeft gelezen en begrepen.

Breng geen veranderingen aan en voer geen onderhoudswerkzaamheden uit die niet in deze handleiding vermeld staan.

De fabrikant kan niet verantwoordelijk worden gehouden voor lichamelijke schade of schade aan eigendommen die zijn veroorzaakt door verkeerd gebruik van de machine of het onjuist interpreteren van de handleiding.



In geval van twijfel of problemen bij het gebruik raadpleeg uw leverancier.



1.1 Gebruiksomgeving

- Iedere machine mag alleen worden gebruikt voor de werkzaamheden waarvoor hij is ontworpen, op de manier zoals is voorschreven op de gegevensplaat en/of deze handleiding, in overeenstemming met de nationale en internationale veiligheidsvoorschriften. Oneigenlijk gebruik zal worden gezien als absoluut ongepast en gevaarlijk en in een dergelijk geval zal de fabrikant iedere verantwoordelijkheid afwijzen.
- De machine dient uitsluitend professioneel gebruikt te worden in een industriële omgeving.
- De fabrikant is niet verantwoordelijk voor schade veroorzaakt door het gebruik van de machine in een huiselijke omgeving.
- De omgevingstemperatuur voor gebruik van de machine moet liggen tussen -10° C en +40° C (Tussen +14°F en +104°F). Voor transport en opslag moet de temperatuur liggen tussen -25°C en +55°C (tussen -13°F en +131°F).
- De machine moet worden gebruikt in een stofvrije omgeving zonder zuren, gas of andere corrosieve stoffen.
- De vochtigheidsgraad van de werkomgeving van de machine mag niet hoger zijn dan 50% bij 40°C (104°F). De vochtigheidsgraad van de werkomgeving van de machine mag niet hoger zijn dan 90% bij 20°C (68°F).
- De machine kan worden gebruikt tot op een hoogte van 2000 meter boven de zeespiegel (6500 voet).

1.2 Bescherming voor de lasser en anderen



Overtuig u ervan dat de koelunit is uitgeschakeld vóór u de aan- en afvoerpijp voor de koel vloeistof los maakt. De hete vloeistof die uit de pijpen komt zou ernstige brandwonden kunnen veroorzaken.



Houd een verbanddoos binnen handbereik. Onderschat brandwonden of andere verwondingen nooit.



Overtuigt u er voor dat u vertrekt van dat de werkplek goed is opgeruimd, zo voorkomt u ongevallen.



1.3 Beveiliging tegen elektrische schokken

- Elektrische schokken kunnen dodelijk zijn.
- Raak geen onderdelen aan noch aan de binnen noch aan de buitenkant van de machine terwijl die is ingeschakeld. (toortsen, klemmen, aardkabels, elektroden, snoeren, rollen en spoelen kunnen onder stroom staan.)
- Overtuigt u ervan dat zowel de lasmachine als de lasser goed geïsoleerd zijn door voor een droge ondergrond te zorgen die goed geïsoleerd is.



1.4 Elektromagnetische velden en storingen

EMC classificatie van apparatuur in overeenstemming met EN/IEC 60974-10 (Zie het kwalificatie plaatje of de technische informatie)

Klasse B apparatuur voldoet aan de elektromagnetische eisen van aansluiting zowel wat betreft de industriële omgeving als de woonomgeving, inclusief de woonomgeving waar de stroomvoorziening wordt betrokken van het netwerk en dus met een lage spanning.

Klasse A apparatuur is niet bedoeld om te gebruiken in de woonomgeving waar de stroom geleverd wordt via het normale netwerk met lage spanning.

In een dergelijke omgeving kunnen zich potentiële moeilijkheden voordoen bij het veilig stellen van de elektromagnetische aansluiting van klasse A apparatuur veroorzaakt door geleiding of storing door straling.

Installatie, gebruik en inspectie van de ruimte.

Deze apparatuur is gebouwd volgens de aanwijzingen in de geharmoniseerde norm EN60974-10 en wordt gerekend tot de Klasse A. Deze apparatuur dient uitsluitend voor professionele doeleinde te worden gebruikt.

De fabrikant kan niet aansprakelijk worden gesteld voor schade veroorzaakt door gebruik van de apparatuur in een huishoudelijke omgeving.



De gebruiker moet een vakkundig iemand zijn die zich verantwoordelijk voelt voor de apparatuur en er gebruik van maakt volgens de richtlijnen van de fabrikant.

Wanneer zich elektromagnetische storingen voordoen moet de lasser de problemen oplossen zonedig met de technische assistentie van de fabrikant.



In ieder geval dient de elektromagnetische storing zodanig gereduceerd te worden dat het geen hinder meer vormt.



Voor de installatie dient de gebruiker de risico's te evalueren die elektromagnetische storingen zouden kunnen opleveren voor de directe omgeving, hierbij in het bijzonder lettend op de gezondheidsrisico's voor personen op en in de omgeving van de werkplek, bij voorbeeld mensen die een pacemaker of een gehoorapparaat hebben.

Afscherming

Door het selectief afschermen van andere kabels en apparatuur in de directe omgeving kunnen de storingsproblemen afnemen. Bij speciale toepassingen kan het worden overwogen de gehele las/snij installatie af te schermen.



1.5 IP Beveiligingsvermogen

IP23S

- Kast voorkomt dat gevaarlijke onderdelen met de vingers of voorwerpen met een diameter tot 12.5mm kunnen worden aangeraakt.
- De kast beschermt tegen inregenen tot een hoek van 60° in verticale stand.
- De kast beschermt tegen de gevolgen van binnen druppelend water als de machine niet aanstaat.



1.6 Koelvloeistof

1.6.1 Persoonlijke bescherming



Inslikken van het product is schadelijk. Het kan irritatie veroorzaken aan de ogen, slijmvlies en de huid.



Gebruik rubber handschoenen om aanraking te voorkomen.



Maak gebruik van een veiligheidsbril tegen spetters.



Draag normale werkkleding zodat contact met de huid wordt voorkomen.

1.6.2 Afval



Na gebruik moeten gelekte vloeistof en andere afvalresten van het product op de juiste manier opgeruimd of indien mogelijk gerecycled worden. Het is verboden de resten weg te spoelen in open water, sloten of afwateringsystemen. De verdunde vloeistof mag niet worden geloosd in het riool tenzij met toestemming van de plaatselijke autoriteiten.

2 INSTALLATIE



Het installeren mag alleen worden gedaan door vakkundig personeel van uw leverancier.



Overtuig u ervan dat tijdens de installatie de stroombron is uitgeschakeld.



2.1 Procedure voor het optillen, vervoeren en uitladen

- De installatie is niet voorzien van een handgreep voor het tillen.



Onderschat het gewicht van de apparatuur niet, zie de technische specificatie.

Hijs en manoeuvreer het apparaat nooit boven personen of voorwerpen.



Laat het apparaat niet vallen of botsen.



2.2 Plaatsen van de installatie

Houdt u aan de volgende richtlijnen.

- Zorg ervoor dat de installatie en de aansluitingen goed toegankelijk zijn.
- Plaats het apparaat niet in een te kleine ruimte.
- Plaats het apparaat niet op een schuin aflopende ondergrond van meer dan 10° waterpas.
- Plaats het apparaat in een droge, schone en goed geventileerde ruimte.
- Bescherm het apparaat tegen hevige regen en tegen de zon.

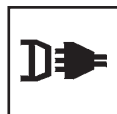

2.3 Aansluiting

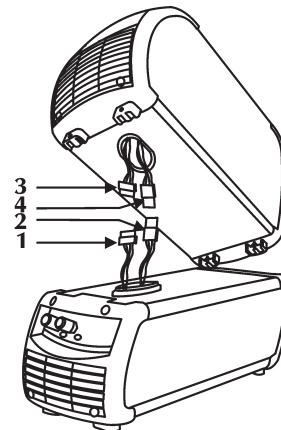

De koelunit is voorzien van een stekker 1 voor aansluiting op de lasmachine.

De koelunit is voorzien van een stekker 2 voor aansluiting op de lasmachine.



Sluit de stroomtoevoer af voordat u de machine aansluit.

- Open de deur onderaan de generator door de twee schroeven los te draaien.
- Verbindt het elektrische aansluitstuk man 1 van de koelunit met het elektrisch aansluitstuk vrouw 2 van de generator.
- Verbindt het elektrische aansluitstuk man 3 van de koelunit met het elektrisch aansluitstuk vrouw 4 van de generator.



2.4 Installatie

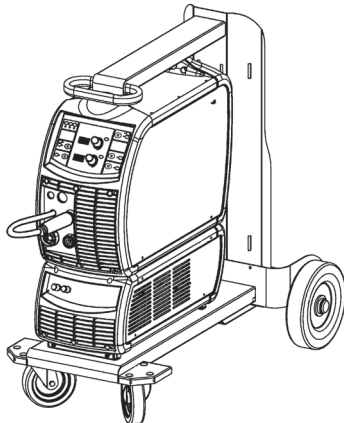

- Zet de WU op de GT en zet hem vast met vier schroeven (1).
- Plaats de generator bovenop de koelunit en zet hem vast met de schroeven.



Voer de volgende handelingen uit voor u de unit start:

- Verwijder de dop van de bijvul tuit.
- Verwijder de afsluit dop van de bijvul tuit, wip hem omhoog met een stuk gereedschap onder de rand van de dop.
- Vul zonnodig de tank met koelvloeistof.
- Bewaar de afsluitdop voor wanneer u de unit moet vervoeren.

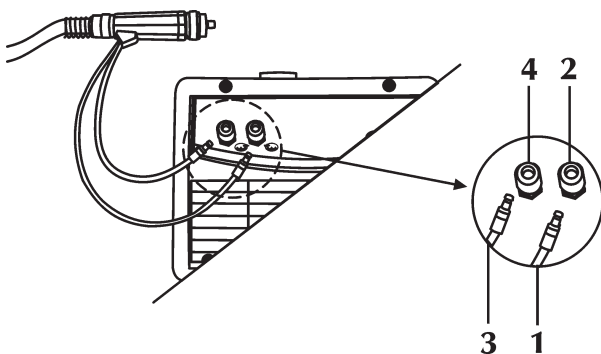

- Verbind de rode kabel van de toorts (1) aan de juiste snelkoppeling (2) (rode kleur – symbool )
- Verbind de blauwe kabel van de toorts (3) aan de juiste snelkoppeling (4) (blauwe kleur – symbool )



Om schade aan de koelunit te voorkomen dient u de bypass leiding altijd aan te sluiten als de toorts nog niet is verbonden met de aan- en afvoerleidingen van de koelvloeistof.



U moet de tank vullen of bijvullen met koelvloeistof, code 18.91.001.

3 PRESENTATIE VAN INSTALLATIE

3.1 Voor paneel

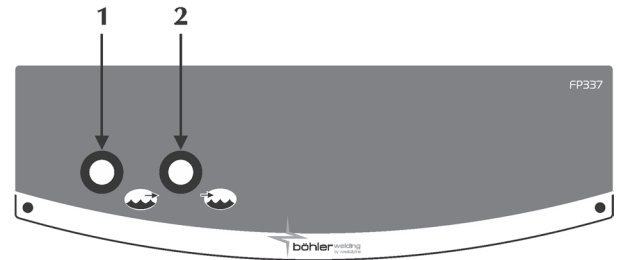

- 1 Verbindingsstuk/uitlaatkoppeling koelvloeistof**
 Om vloeistof met een lage temperatuur in het koelcircuit van de toorts te doen.
- 2 Verbindingsstuk/inlaatkoppeling koelvloeistof**
 Om vloeistof die door de toorts sterk is verwarmd terug te doen in het koelcircuit van de WU.

4 ONDERHOUD



De normale onderhoud werkzaamheden moeten worden uitgevoerd volgens de richtlijnen die de fabrikant heeft verstrekt.

Iedere onderhoud beurt dient te worden gedaan door gekwalificeerd personeel.

Als de machine is ingeschakeld moeten alle ingangspunten en panelen zijn gesloten.

Niet goedgekeurde veranderingen aan de machine zijn ten strengste verboden.

Voorkom ophoping van metaalstof bij of op de roosters.



Schakel de stroomtoevoer altijd uit voor u onderhoud pleegt.



Controleer regelmatig het niveau van de koelvloeistof. Als de tank helemaal leeg is of als er lucht in de leidingen zit kan de pomp haperen.

- Controleer de hoeveelheid vloeistof in de tank (2/3 water en 1/3 antivries vloeistof)
- Reinig de binnenkant van het toestel door het schoon te blazen met perslucht onder lage druk of met een zachte borstel.
- Controleer de elektriciteitsnoeren en alle verbindingkabels.
- Controleer de staat van de elektrische pomp.
- Controleer de staat van de slangklemmen.

Ververs iedere zes maanden de koelvloeistof en reinig de slangen en de tank met water. Vervang de vloeistof als het heeft gekookt omdat daardoor de beschermende eigenschappen verloren zijn gegaan.



Het vullen of bijvullen van de tank met koelvloeistof moet worden gedaan met de generator en de WU samengevoegd en geplaatst op een horizontale ondergrond.



Het vullen of bijvullen van de tank moet gebeuren met koelvloeistof, code 18.91.001.

De apparatuur mag niet worden gebruikt zonder koelvloeistof.



Gebruik geen geleidende koelvloeistoffen.

Als niet aan bovenstaande onderhoud wordt voldaan vervalt de garantie en wordt de fabrikant van alle aansprakelijkheid ontheven.

5 DIAGNOSE EN OPLOSSINGEN



De reparatie of vervanging van een onderdeel in de machine dient te worden gedaan door gekwalificeerd personeel.

Bij reparatie of vervanging van een onderdeel in de machine door onbevoegd personeel vervalt de garantie.

Er mag geen enkele wijziging in de apparatuur worden aangebracht.

De fabrikant wijst ieder verantwoordelijkheid af wanneer de gebruiker zich niet houdt aan deze richtlijnen.

Geen vloeistof in het circuit

Vraag Geen vloeistof in de tank.

Oplossing Vloeistof bijvullen.

Vraag Lucht in het koelcircuit.

Oplossing Verbind de by-pass met de outlet aansluiting  (kleur blauw) en tapt het hydraulische circuit af waardoor de koelvloeistof binnen enkele seconden te voorschijn komt.

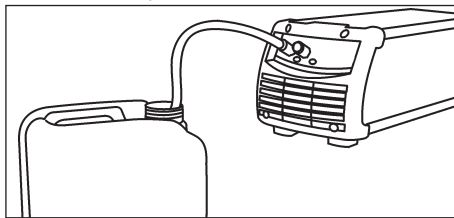

Vraag Koelcircuit verstopt of onderbroken.

Oplossing Controleer de status van de verbindingen van het hydraulische circuit (binnen in de unit).

Controleer de status van het hydraulische circuit van de toorts.

Controleer de toestand van het hydraulisch circuit van de kabelbundel.

Neem contact op met uw leverancier om de machine te repareren.

Oorzaak De aanwezigheid van het koelunit alarm.

Oplossing Reset het alarm.

Verbind een toorts of de by-pass bij een ingeschakelde stand waarbij de koelunit aan moet staan.

Controleer de status van de verbindingen van het hydraulische circuit (binnen in de unit).

Controleer de status van het hydraulische circuit van de toorts.

Neem contact op met uw leverancier om de machine te repareren.

Vraag Pomp defect.

Oplossing Vervang de schakelaar.

Neem contact op met uw leverancier om de machine te laten repareren.

Onvoldoende koelvermogen

Vraag Ventilator defect.

Oplossing Vervang de schakelaar.

Neem contact op met uw leverancier om de machine te laten repareren.

Vraag Pomp defect.

Oplossing Vervang de schakelaar.

Neem contact op met uw leverancier om de machine te laten repareren.

6 TECHNISCHE KENMERKEN

WU 330	
Netspanning U1	1x400 V
Opgenomen stroom I1max	0.5 A
Koelvermogen (25°C)	1.0 Kw
Type warmtewisselaar	H2O - Lucht
Nominale doorstroom snelheid (QV)	2.3 l/min
Maximale doorstroom snelheid (Qvmax)	4.6 l/min
Opvoerhoogte pomp (Hmax)	35 m
Type pomp	Roterende
Maximaal toerental	2900 min
IP beveiligingsvermogen	IP23S
Tank inhoud	5.5 l
Afmetingen (lxbxh)	705x305x250 mm
Gewicht	15.0 Kg.
Constructie normen	EN 60974-2/EN 60974-10

FÖRSÄKRAN OM ÖVERENSSTÄMMELSE

Företaget

SELCO s.r.l. - Via Palladio, 19 - 35019 ONARA DI TOMBOLO (Padova) - ITALY

Tel. +39 049 9413111 - Fax +39 049 9413311 - E-mail: selco@selcoweld.com - www.selcoweld.com

försäkrar att apparaten

WU 330

överensstämmer med direktiven EU:

**2014/35/EU LOW VOLTAGE DIRECTIVE
2014/30/EU EMC DIRECTIVE
2011/65/EU RoHS DIRECTIVE**

och att följande bestämmelser har tillämpats:

**EN 60974-2:2014
EN 60974-10:2015 Class A**

Ingrepp eller modifieringar utan tillstånd av **SELCO s.r.l.** medför att denna försäkran inte längre är giltig.

Onara di Tombolo (PADOVA)

Firmatecknare



Lino Frasson

INNEHÅLLSFÖRTECKNING

1 VARNING.....	47
1.1 Driftsmiljö.....	47
1.3 Skydd mot elektriska urladdningar	47
1.4 Elektromagnetiska fält och störningar	47
1.5 IP-skyddsgrad.....	48
1.6 Kylvätska.....	48
1.6.1 Personskydd.....	48
1.6.2 Avfallshantering.....	48
2 INSTALLATION	48
2.1 Lyftning, transport och lossning.....	48
2.2 Aggregatets placering	48
2.3 Inkoppling	48
2.4 Igångsättning.....	49
3 BESKRIVNING AV AGGREGATET	49
3.1 Främre panel	49
4 UNDERHÅLL.....	49
5 FELSÖKNING OCH TIPS.....	50
6 TEKNISKA DATA.....	50

SYMBOLER



Överhängande fara som orsakar allvarlig skada och riskbeteende som kan orsaka allvarlig skada



Beteende som kan orsaka lättare personskador eller sakskador

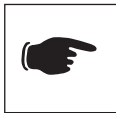

Tekniska anmärkningar som underlättar arbetet

1 VARNING



Läs den här instruktionsboken ordentligt och se till att du har förstått anvisningarna innan du börjar arbeta med maskinen.

Modifiera inte maskinen och utför inget underhåll som inte anges här.

Tillverkaren påtar sig inget ansvar för person- eller sakskador som uppkommer till följd av att denna instruktionsbok inte har lästs uppmärksamts eller att instruktionerna i den inte har följts.



Rådfråga fackman om du är tveksam till hur aggregatet ska användas eller om du får problem.



1.1 Driftsmiljö

- Aggregaten får endast användas för de ändamål som de har konstruerats för, på de sätt och de områden som anges på märkplåten och/eller i denna instruktionsbok, i enlighet med nationella och internationella säkerhetsnormer. Användning som avviker från vad tillverkaren uttryckligen har föreskrivit ska betraktas som helt olämplig och farlig. Tillverkaren påtar sig inget ansvar i sådana fall.
- Denna apparat får endast användas för professionellt bruk i industrimiljö.
Tillverkaren påtar sig inget ansvar för skador som orsakas av att aggregatet används i hemmiljö.
- Aggregatet ska användas i omgivningar med temperatur på mellan -10 °C och +40 °C (mellan +14 °F och +104 °F).
Aggregatet ska transporteras och förvaras i omgivningar med temperatur på mellan -25 °C och +55 °C (mellan -13 °F och +131 °F).
- Miljön ska vara fri från damm, syror, gaser och andra frätande ämnen.
- Den relativa luftfuktigheten ska vara högst 50 % vid 40 °C (104 °F).
- Den relativa luftfuktigheten ska vara högst 90 % vid 20 °C (68 °F).
- Aggregatet får användas på en höjd av högst 2000 m över havet (6500 fot).

1.2 Personligt skydd och skydd för tredje man



Kontrollera att kylvätskan är avstängd innan du kopplar loss matarslangen och returslangen för kylvätskan. Den heta vätskan kan ge allvarliga brännskador.



Ha första hjälpen-utrustning tillgänglig.
Banalisera inte brännskador eller sår.



Säkra det område du ansvarar för innan du lämnar arbetsplatsen, för att motverka risken för person- och sakskador.



1.3 Skydd mot elektriska urladdningar

- Elektriska urladdningar kan vara livsfarliga.
- Undvik att vidröra delar som normalt är spänningsförande inuti eller utanför svets-/skärregulatort när det är strömförsörjt (brännare, gripklor, jordledare, elektroder, trådar, valsar och rullar är elektriskt anslutna till svetskretsen).
- Se till att aggregatet och operatören isoleras elektriskt genom att använda torra plan och underreden som är tillfredsställande isolerade från nollpotentialen och jordpotentialen.



1.4 Elektromagnetiska fält och störningar

Utrustning som EMC-klassificeras i enlighet med EN/IEC 60974-10 (Se märkplåten eller tekniska data)

Utrustning i klass B följer kraven på elektromagnetisk kompatibilitet för industri- och boendemiljöer, inklusive för bostadsområden där el levereras via det allmänna lågspänningsnätet.

Utrustning i klass A är inte avsedd för bruk i bostadsområden där el levereras via det allmänna lågspänningsnätet. Det kan vara svårt att garantera elektromagnetisk kompatibilitet för utrustning i klass A på sådana platser, på grund av såväl ledningsbundna som strålade störningar.

Installation, drift och omgivningsbedömning

Denna apparat är konstruerad i överensstämmelse med anvisningarna i den harmoniserade standarden EN60974-10 och tillhör Klass A.

Denna apparat får endast användas för professionellt bruk i industrimiljö.

Tillverkaren påtar sig inget ansvar för skador som orsakas av att aggregatet används i hemmiljö.



Användaren ska vara expert på området och är som sådan ansvarig för att apparaten installeras och används enligt tillverkarens anvisningar.

Vid eventuella elektromagnetiska störningar ska användaren lösa problemet med hjälp av tillverkarens tekniska service.



De elektromagnetiska störningarna måste alltid minskas så mycket att de inte medför besvär.



Innan apparaten installeras ska användaren bedöma vilka eventuella elektromagnetiska problem som kan uppstå i det omgivande området och särskilt hälsotillståndet hos personalen i området, till exempel de som använder pacemakrar eller hörapparater.

Skärmning

Selektiv skärmning av andra kablar och apparater i omgivningarna kan minska störningsproblemen. För speciella applikationer kan man överväga att skärma hela svets-/skäranläggningen.



1.5 IP-skyddsgrad

IP23S

- Höljet förhindrar att man kommer åt farliga delar med fingrarna och skyddar mot fasta främmande föremål med en diameter på 12,5 mm eller mer.
- Höljet skyddar mot regn i 60° vinkel mot vertikalled.
- Höljet är skyddat mot skador till följd av inträngande vatten när utrustningens rörliga delar inte är i rörelse.



1.6 Kylvätska

1.6.1 Personskydd



Produkten är farlig att förtära. Kan irritera ögon, slemhinnor och hud.



Använd gummihandskar för att undvika direktkontakt med produkten.



Använd skyddsglasögon för att undvika stänk i ögonen.



Använd normala arbetskläder för att undvika hudkontakt.

1.6.2 Avfallshantering



När produkten har använts för sitt ändamål ska spill eller rester behandlas i lämplig reningsanläggning eller om möjligt återanvändas. Använd produkt får inte tömmas ut i vattendrag, diken eller avloppssystem. Utspädd vätska får inte tömmas ut i avloppet om detta inte är tillåtet enligt lokala bestämmelser.

2 INSTALLATION



Endast personal med specialkunskaper och tillstånd från tillverkaren får installera kylenheten.



Se till att generatorm är ansluten till elnätet innan installationen görs.



2.1 Lyftning, transport och lossning

- Aggregatet har inga särskilda lyftanordningar.



Underskatta inte aggregatets vikt, se tekniska data.



Förflytta eller stoppa inte lasten ovanför människor eller föremål.

Låt inte aggregatet eller en enskild enhet falla eller ställas ned med en kraftig stöt.



2.2 Aggregatets placering

Tillämpa följande kriterier:

- Kommandon och kopplingar ska vara lättillgängliga.
- Placera inte utrustningen i trånga utrymmen.
- Placera inte aggregatet på ett plan som lutar mer än 10° i relation till horisontalplanet.
- Placera aggregatet på torr plats med god ventilation.
- Skydda aggregatet mot regn och direkt solljus.



2.3 Inkoppling

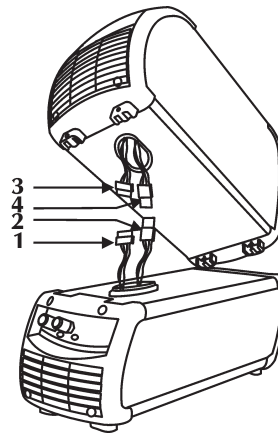

Kylenheten har ett kontaktdon 1 för anslutning till svetsaggregatet.

Kylenheten har ett kontaktdon 2 för anslutning till svetsaggregatet.



Stäng av strömförsörjningen till aggregatet före alla ingrepp!

- Lossa de två skruvarna på generatorns nedre huv och öppna luckan.
- Anslut kylenhetens hankontakt 1 till generatorns honkontakt 2.
- Anslut kylenhetens hankontakt 3 till generatorns honkontakt 4.



2.4 Igångsättning

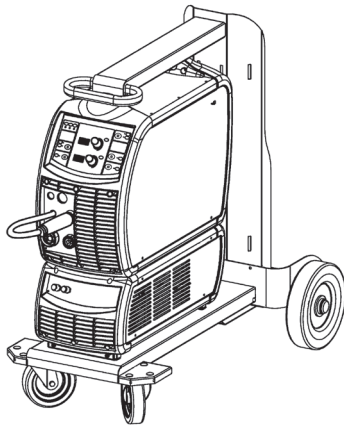



- Placera WU ovanpå GT och fäst den med de 4 skruvarna (1).
- Placera generatorm på kylenheten och fäst den med skruvarna.

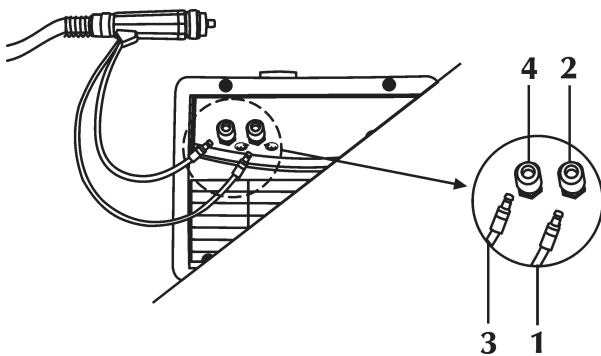

Innan du sätter igång enheten:

- Ta loss proppen från behållaren.
- Ta loss den lufttäta proppen ur intagskanalen genom att bända längs kanten av proppen med ett verktyg.
- Fyll vid behov på vätska i behållaren.
- Ta vara på den lufttäta proppen för den händelse att enheten ska transporteras i framtiden.



- Anslut returslangen för kylvätska från brännaren (1) (röd) till kopplingen (2) (röd - symbol ).
- Anslut matarslangen för kylvätska till brännaren (3) (blå) till kopplingen (4) (blå - symbol ).



Montera alltid förbiledningsslangen när brännaren inte är ansluten till in- och utgångarna för kylvätska för att inte skada kylenheten.



Vid påfyllning av behållaren ska kylvätska med art.nr 18.91.001 användas.

3 BESKRIVNING AV AGGREGATET

3.1 Främre panel

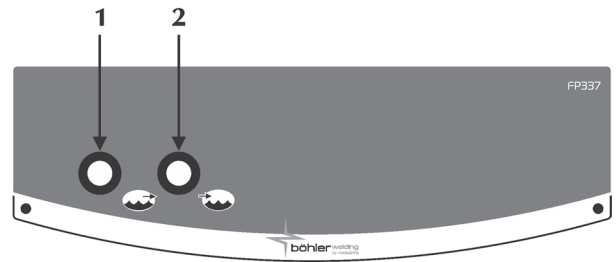

1 Koppling för kylvätskeutlopp



Används för att föra in vätska med låg temperatur i brännarens kylkrets.

2 Koppling för kylvätskeinlopp



Används för att föra in vätska som har värmts upp av brännaren i WUs kylkrets.

4 UNDERHÅLL



Anläggningen ska genomgå löpande underhåll i enlighet med tillverkarens instruktioner.

Eventuellt underhåll får endast utföras av utbildad personal. Alla luckor och kåpor ska vara stängda och ordentligt fastsatta när apparaten är i drift.

Anläggningen får inte modifieras på något sätt.

Om detta underhåll inte utförs upphör alla garantier att gälla och tillverkaren kan inte utkrävas något ansvar för konsekvenserna.



Stäng av strömförsörjningen till aggregatet före alla ingrepp!



Kontrollera kylvätskenivån i behållaren med jämna mellanrum. Om behållaren töms helt och/eller om det finns luft i pumpen kan det hända att pumpen inte startar.

- Kontrollera vätskemängden i behållaren (2/3 vatten och 1/3 frostskyddsmedel).
- Rengör generatorm invändigt med tryckluft med lågt tryck och pensel med mjuk borst.
- Kontrollera de elektriska anslutningarna och alla kabelkopplingar.
- Kontrollera motorpumpens skick.
- Kontrollera slanganslutningarna.

Byt kylvätska en gång i halvåret och spola slangarna och behållaren med vatten. Byt kylvätska om den skulle koka, eftersom den då förlorar sina skyddande egenskaper.



Påfyllning av kylvätska i behållaren ska göras när generatorm och WU är ihopmonterade och står på ett horisontellt plan.



Vid påfyllning av behållaren ska kylvätska med art.nr 18.91.001 användas.

Använd inte utrustningen utan kylvätska.



Använd inte ledande kylvätska.

Om detta underhåll inte utförs upphör alla garantier att gälla och tillverkaren kan inte utkrävas något ansvar för konsekvenserna.

5 FELSÖKNING OCH TIPS



Eventuella reparationer och utbyte av delar av aggregatet får endast utföras av kompetent teknisk personal.

Om obehörig personal reparerar aggregatet eller byter ut delar av det upphör produktgarantin omedelbart att gälla. Aggregatet får inte modifieras på något sätt.

Tillverkaren påtar sig inget ansvar om operatören inte följer dessa anvisningar.

Flöde saknas i kretsen

Orsak Vätskebrist i behållaren.

Lösning Fyll på med vätska.

Orsak Luft i kylkretsen.

Lösning Koppla förbikopplingsledningen till utloppsanslutningen  (blå) och lufta hydraulkretsen så att kylvätskan kommer fram några sekunder.

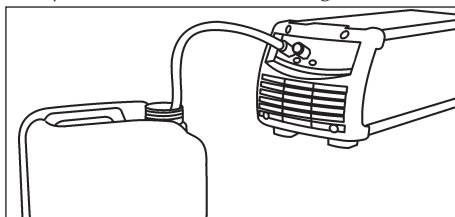

Orsak Kylkretsen blockerad eller trasig.

Lösning Kontrollera anslutningarnas skick (inuti enheten) i hydraulkretsen.
Kontrollera brännarens hydraulkrets.
Kontrollera kylkretsens status i kabelknippet.
Kontakta närmaste serviceverkstad för reparation av aggregatet.

Orsak Kylvenslarmet aktiverat.

Lösning Återställ larmet.
Anslut en brännare eller förbikopplingsledning i de funktionslägen där kylvenslarmet måste vara aktiv.
Kontrollera anslutningarnas skick (inuti enheten) i hydraulkretsen.
Kontrollera brännarens hydraulkrets.
Kontakta närmaste serviceverkstad för reparation av aggregatet.

Orsak Trasig pump.

Lösning Byt ut den skadade komponenten.
Kontakta närmaste serviceverkstad för reparation av aggregatet.

Otillräcklig kylkapacitet

Orsak Trasig fläkt.

Lösning Byt ut den skadade komponenten.
Kontakta närmaste serviceverkstad för reparation av aggregatet.

Orsak Trasig pump.

Lösning Byt ut den skadade komponenten.
Kontakta närmaste serviceverkstad för reparation av aggregatet.

6 TEKNISKA DATA

WU 330	
Nätspänning U1	1x400 V
Strömförbrukning I1 max	0.5 A
Kyleffekt (25°C)	1.0 Kw
Typ av värmväxlare	H2O - Luft
Nominell kapacitet (QV)	2.3 l/min
Maximikapacitet (Qvmax)	4.6 l/min
Uppfordring pump (Hmax)	35 m
Typ av pump	Rotationspump
Maximalt varvtal	2900 min
Skyddsgrad IP	IP23S
Isoleringsklass	5.5 l
Mått (lxbxh)	705x305x250 mm
Vikt	15.0 Kg.
Konstruktionsbestämmelser	EN 60974-2/EN 60974-10

EF-OVERENSSTEMMELSESERKLÆRING

Firmaet

SELCO s.r.l. - Via Palladio, 19 - 35019 ONARA DI TOMBOLO (Padova) - ITALIEN
Tlf. +39 049 9413111 - Fax +39 049 9413311 - E-mail: selco@selcoweld.com - www.selcoweld.com

erklærer, at apparatet af typen

WU 330

er i overensstemmelse med følgende EU-direktiver:

2014/35/EU LOW VOLTAGE DIRECTIVE
2014/30/EU EMC DIRECTIVE
2011/65/EU RoHS DIRECTIVE

og at følgende standarder er bragt i anvendelse:

EN 60974-2:2014
EN 60974-10:2015 Class A

Ethvert indgreb eller enhver ændring, der ikke er autoriseret af **SELCO s.r.l.**, vil medføre, at denne erklæring ikke længere er gyldig.

Onara di Tombolo (PADOVA)

Selco s.r.l.



Lino Frasson
Chief Executive

INDHOLDSFORTEGNELSE

1 ADVARSEL	53
1.1 Brugsomgivelser	53
1.2 Personlig beskyttelse og beskyttelse af andre	53
1.3 Beskyttelse mod elektrisk stød.....	53
1.4 Elektromagnetiske felter og forstyrrelser.....	53
1.5 IP-beskyttelsesgrad	54
1.6 Kølevæske.....	54
1.6.1 Personbeskyttelse.....	54
1.6.2 Bortskaffelse.....	54
2 INSTALLERING.....	54
2.1 Løfte-, transport- og aflæsningsanvisninger	54
2.2 Placering af anlægget	54
2.3 Tilslutning	54
2.4 Idriftsættelse	55
3 PRÆSENTATION AF ANLÆGGET.....	55
3.1 Det frontale betjeningspanel	55
4 VEDLIGEHOLDELSE.....	55
5 FEJLFINDING OG LØSNINGER.....	56
6 TEKNISKE SPECIFIKATIONER	56

SYMBOLER



Overhængende fare, der kan medføre alvorlige legemsbeskadigelser, samt farlige handlemåder, der kan forårsage alvorlige læsioner



Handlemåder, der kan medføre mindre alvorlige legemsbeskadigelser eller beskadigelse af ting



Bemærkninger med dette symbol foran er af teknisk karakter og gør indgrebene lettere at udføre

1 ADVARSEL



Inden der udføres nogen form for indgreb, skal man have læst og forstået denne vejledning.

Der må ikke udføres ændringer på maskinen eller vedligeholdelse, der ikke er beskrevet i vejledningen.

Fabrikanten påtager sig intet ansvar for legemsbeskadigelser eller beskadigelse af ting, forårsaget af misbrug eller manglende udførelse af indholdet i denne vejledning.



Tag kontakt til en fagmand i tilfælde af tvivl eller problemer vedrørende anlæggets brug.



1.1 Brugsomgivelser

- Ethvert anlæg må udelukkende benyttes til dets forudsete brug, på de måder og områder, der er anført på dataskiltet og/eller i denne vejledning, og i henhold til de nationale og internationale sikkerhedsforskrifter. Anden brug end den, fabrikanten udtrykkeligt har angivet, skal betragtes som uhenigtsmæssig og farlig og vil fritage fabrikanten for enhver form for ansvar for skade.
- Dette apparat må udelukkende anvendes til professionelle formål i industrielle omgivelser. Fabrikanten fralægger sig ethvert ansvar for skader forårsaget af anlæggets brug i private omgivelser.
- Anlægget skal anvendes i omgivelser med en temperatur på mellem -10°C og +40°C (mellem +14°F og +104°F). Anlægget skal transporteres og opbevares i omgivelser med en temperatur på mellem -25°C og +55°C (mellem -13°F og 131°F).
- Anlægget skal benyttes i omgivelser uden støv, syre, gas eller andre ætsende stoffer.
- Anlægget skal benyttes i omgivelser med en relativ luftfugtighed på højst 50 % ved 40°C (104°F). Anlægget skal benyttes i omgivelser med en relativ luftfugtighed på højst 90 % ved 20°C (68°F).
- Anlægget må ikke benyttes i en højde over havet på over 2000m (6500 fod).

1.2 Personlig beskyttelse og beskyttelse af andre



Kontrollér, at kølegruppen er slukket, inden kølevæskens tilførsels- og afledningsslanger kobles fra. Den varme væske, der løber ud af rørene, kan forårsage alvorlige skoldninger eller forbrændinger.



Sørg for, at der er førstehjælpsudstyr til rådighed. Undervurder aldrig forbrændinger og sår.



Genopret sikre forhold i området, inden arbejdsområdet forlades, således at utilsigtet skade på personer og genstande undgås.



1.3 Beskyttelse mod elektrisk stød

- Et elektrisk stød kan være dødbringende.
- Undgå berøring af strømførende dele både inden i og uden på svejse-/skæreanlægget, så længe anlægget er under forsyning (brændere, tænger, jordforbindelseskabler, elektroder, ledninger, valser og spoler er elektrisk forbundet til svejsekredsløbet).
- Sørg for, at anlæg og svejser er elektrisk isoleret ved hjælp af tørre plader og sokler med tilstrækkelig isolering mod mulig jordforbindelse.



1.4 Elektromagnetiske felter og forstyrrelser

Klassificering af udstyrs elektromagnetiske kompatibilitet (EMC) i overensstemmelse med EN/IEC 60974-10 (Se typeskilt eller teknisk data)

Udstyr i klasse B overholder kravene vedrørende elektromagnetisk kompatibilitet i industrielle miljøer og private boliger, herunder boligområder, hvor elektriciteten leveres via det offentlige lavspændingsforsyningsnet.

Udstyr i klasse A er ikke beregnet til brug i boligområder, hvor elektriciteten leveres via det offentlige lavspændingsforsyningsnet. Der kan være visse vanskeligheder med at sikre elektromagnetisk kompatibilitet for klasse A-udstyr i sådanne områder på grund af ledningsbårne forstyrrelser og strålingsforstyrrelser.

Installering, brug og vurdering af området

Dette apparat er bygget i overensstemmelse med kravene i den harmoniserede standard EN60974-10 og er identificeret som et "KLASSE A"-apparat.

Dette apparat må udelukkende anvendes til professionelle formål i industrielle omgivelser.

Fabrikanten fralægger sig ethvert ansvar for skader forårsaget af anlæggets brug i private omgivelser.



Brugeren skal have ekspertise indenfor arbejdsområdet, og han/hun er i denne henseende ansvarlig for installering og brug af apparatet i overensstemmelse med fabrikantens anvisninger. Hvis der opstår elektromagnetiske forstyrrelser, er det brugerens opgave at løse problemet med hjælp fra fabrikantens tekniske servicetjeneste.



Elektromagnetiske forstyrrelser skal under alle omstændigheder reduceres i en sådan grad, at de ikke længere har nogen indflydelse.



Inden dette apparat installeres, skal brugeren vurdere de eventuelle elektromagnetiske problemer, der kan opstå i det omkringliggende område, specielt hvad angår de tilstedeværende personers sundhedstilstand, fx: brugere af pacemakere og høreapparater.

Afskærmning

Afskærmning af udvalgte kabler og apparater i det omkringliggende område kan løse interferensproblemer. Muligheden for afskærmning af hele svejse-/skæreanlægget kan overvejes i specielle arbejdssituationer.



1.5 IP-beskyttelsesgrad

IP23S

- Indkapsling er beskyttet mod indføring af fingre og faste fremmedlegemer med en diameter større end/lig med 12,5 mm og berøring af farlige elementer.
- Indkapslingen er beskyttet mod regn i en vinkel på op til 60° fra lodret position.
- Indkapslingen er beskyttet mod skader forårsaget af vandindtrængning, når apparatets bevægelige dele ikke er i bevægelse.



1.6 Kølevæske

1.6.1 Personbeskyttelse



Helbredsskadelende ved indtagelse. Kan forårsage irritation på øjne, slimhinder og hud.



Undgå berøring, benyt gummihandsker.



Forebyg stænk, benyt sikkerhedsbriller.



Undgå berøring med huden, anvend almindeligt arbejdstøj.

1.6.2 Bortskaffelse



Efter at produktet har været anvendt indenfor det forudsete brugsområde, skal udslip eller rester behandles på et rensningsanlæg eller, om muligt, indgå i en genbrugscyklus. Det er ikke tilladt at udlede det brugte produkt i vandløb, grøfter eller bortledningsystemer. Fortyndet væske bør aldrig bortledes gennem kloaksystemet, med mindre dette er tilladt i de lokale forskrifter.

2 INSTALLERING



Installeringen må kun udføres af erfarent personale, der er godkendt af svejsemaskinens fabrikant.



Ved installering skal man sørge for, at strømkilden er afbrudt fra forsyningsnettet.



2.1 Løfte-, transport- og aflæsningsanvisninger

- Anlægget er ikke udstyret med specifikke løfteelementer.



Undervurder aldrig anlæggets vægt, (læs de tekniske specifikationer).

Lad aldrig læsset glide hen over - eller hænge stille over - personer eller ting.



Lad aldrig anlægget eller de enkelte enheder falde eller støtte mod jordoverfladen med stor kraft.



2.2 Placering af anlægget

Overhold nedenstående forholdsregler:

- Der skal være nem adgang til betjeningsorganerne og tilslutningspunkterne.
- Placér aldrig udstyret i snævre områder.
- Anbring aldrig anlægget på en overflade med en hældning på over 10° i forhold til det vandrette plan.
- Slut anlægget til i et tørt, rent område med en god udluftning.
- Beskyt anlægget mod direkte regn og solstråler.

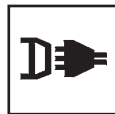

2.3 Tilslutning

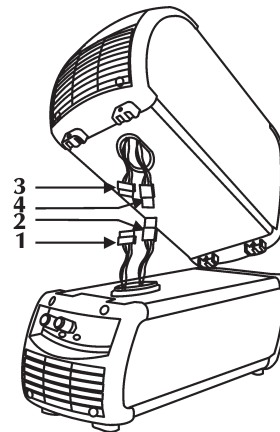

Kølegruppen er udstyret med en 1-tilslutning til generatoren. Kølegruppen er udstyret med en 2-tilslutning til generatoren.



Afbryd strømforsyningen til anlægget inden enhver form for indgreb!

- Åbn lågen i bunden af generatoren ved at fjerne de to skruer.
- Sæt 1-hanstikket på kølegruppen i generatorens 2-hunstik.
- Sæt 3-hanstikket på kølegruppen i generatorens 4-hunstik.



2.4 Idriftsættelse

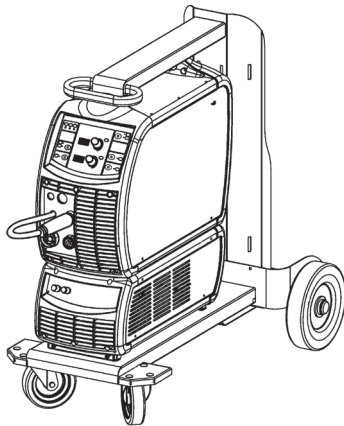



- Placer WU over GT og fastgør med de 4 skruer (1).
- Placer generatoren oven på kølegruppen og fastgør med de relevante skruer.

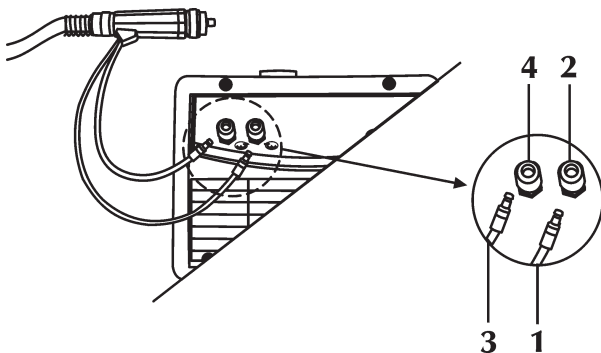

Inden enheden sættes i funktion, skal man udføre følgende handlinger:

- Fjern lukkeproppen fra tanken.
- Fjern proppen med hermetisk lukning fra påfyldningskanalen ved at skubbe opad med et stykke værktøj på proppens kant.
- Fyld om nødvendigt væske i tanken.
- Opbevar proppen med hermetisk lukning til eventuelle fremtidige flytninger af enheden.



- Forbind brænderens kølevæsketilbageledningsslange (1) (rød farve) med det relevante samlestykke/kobling (2) (rød farve - symbol ).
- Forbind brænderens kølevæsketilførselsslange (3) (blå farve) med det relevante samlestykke/kobling (4) (blå farve - symbol ).



For ikke at beskadige afkølingsenheden skal man altid montere by-pass-røret, når brænderen ikke er tilsluttet terminalerne for indgang/udgang for kølevæsken.



Påfyldning eller genopfyldning af tanken skal udføres med kølevæsken kode 18.91.001.

3 PRÆSENTATION AF ANLÆGGET

3.1 Det frontale betjeningspanel

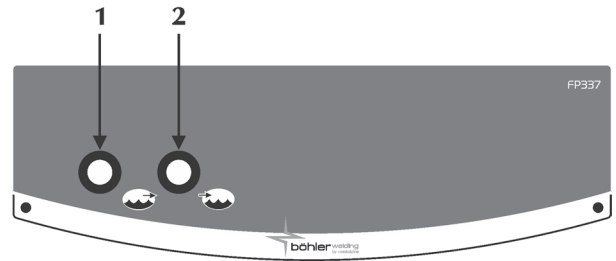

1 Udløbskobling for kølevæske



Gør det muligt at indsprøjte væske med lav temperatur i svejsebrænderens kølekredsløb.

2 Indtagskobling for kølevæske



Gør det muligt at indsprøjte væske, som er blevet opvarmet af svejsebrænderen, i kølekredsløbet i WU.

4 VEDLIGEHOLDELSE



Anlægget skal undergå rutinemæssig vedligeholdelse i henhold til fabrikantens anvisninger.

Al vedligeholdelse skal udelukkende udføres af kvalificeret personale.

Alle adgangslåger, åbninger og dæksler skal være lukket og korrekt fastgjort, når apparatet er i funktion.

Anlægget må aldrig udsættes for nogen form for modifikation. Undgå ophobning af metalstøv i nærheden af eller direkte på udluftningsvingerne.



Afbryd strømforsyningen til anlægget inden enhver form for indgreb!



Kølevæskenniveauet skal kontrolleres regelmæssigt. Hvis beholderen er tom, eller hvis der er luft i kølekredsløbet, vil pumpen ikke opnå tilstrækkelig sugekraft.

- Kontroller væskemængden i beholderen (2/3 vand og 1/3 frostvæske).
- Rengør enheden indvendigt ved hjælp af trykluft med lavt tryk og bløde børster.
- Kontrollér de elektriske tilslutninger og alle forbindelseskablerne.
- **Kontroller elektropumpens tilstand.**
- **Kontroller rørledningstilslutningernes tilstand.**

Hvert halve år skal man skifte kølevæsken og skylle rørene og tanken med vand. Skift væsken, hvis den skulle komme i kog, fordi dette medfører tab af metalbeskyttelsesegenskaberne.



Påfyldning eller genopfyldning af tanken med kølevæske skal udføres med generatoren og WU samlet og anbragt på en vandret overflade.



Påfyldning eller genopfyldning af tanken skal udføres med kølevæsken kode 18.91.001.

Udstyret må ikke anvendes uden kølevæske.



Benyt aldrig ledende kølevæsker.

Ved manglende udførelse af ovennævnte vedligeholdelse vil alle garantier bortfalde, og fabrikanten vil i alle tilfælde være fritaget for alle former for ansvar.

5 FEJLFINDING OG LØSNINGER



Eventuel reparation eller udskiftning af anlægs-elementer må udelukkende udføres af teknisk kvalificeret personale.

Reparation eller udskiftning af anlægs-elementer udført af uautoriseret personale medfører øjeblikkeligt bortfald af produktgarantien.

Anlægget må aldrig udsættes for nogen form for modifikation.

Fabrikanten fralægger sig ethvert ansvar, hvis operatøren ikke overholder disse forskrifter.

Manglende flow i kredsløb

Årsag Mangel på væske i tanken.

Løsning Efterfyld.

Årsag Luft i kølekredsløbet.

Løsning Indsæt shunten på udgangskoblingen  (blå) og udluft hydraulikkredsløbet, hvorved kølevæskens udgang gøres mulig i nogle sekunder.

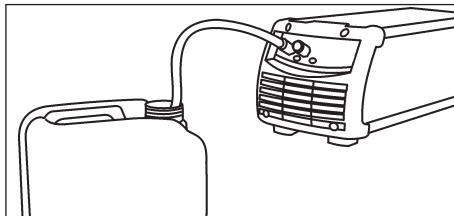

Årsag Kølekredsløbet er tilstoppet eller afbrudt.

Løsning Kontrollér tilslutningernes stand (indvendig i enheden) i hydraulikkredsløbet.

Kontrollér standen af brænderens hydraulikkredsløb. Tjek tilstanden ved kabelbundet hydrauliske kredsløb.

Kontakt nærmeste servicecenter og lad anlægget reparere.

Årsag Alarm i køleenheden.

Løsning Nulstil alarmer.

Tilslut en brænder eller shunten i de funktionsmåder, hvor køleenheden er i aktivitet.

Kontrollér tilslutningernes stand (indvendig i enheden) i hydraulikkredsløbet.

Kontrollér standen af brænderens hydraulikkredsløb. Kontakt nærmeste servicecenter og lad anlægget reparere.

Årsag Defekt pumpe.

Løsning Udskift den defekte komponent.

Kontakt nærmeste servicecenter og lad anlægget reparere.

Utilstrækkelig køleevne

Årsag Defekt blæser.

Løsning Udskift den defekte komponent.

Kontakt nærmeste servicecenter og lad anlægget reparere.

Årsag Defekt pumpe.

Løsning Udskift den defekte komponent.

Kontakt nærmeste servicecenter og lad anlægget reparere.

6 TEKNISKE SPECIFIKATIONER

WU 330	
Forsyningsspænding U1	1x400 V
Absorberet strøm I1max	0.5 A
Køleeffekt (25°C)	1.0 Kw
Varmevekslertype	H2O - Luft
Nominel kapacitet (QV)	2.3 l/min
Maksimal kapacitet (Qvmax)	4.6 l/min
Pumpeløftehøjde (Hmax)	35 m
Pumpetype	Rotor
Maksimalt omdrejningstal	2900 min
IP-beskyttelsesgrad	IP23S
Tankkapacitet	5.5 l
Dimensioner (lxdxh)	705x305x250 mm
Vægt	15.0 Kg.
Bygningsstandarder	EN 60974-2/EN 60974-10

CE - SAMSVARERKLÆRING

Produsenten

SELCO s.r.l. - Via Palladio, 19 - 35019 ONARA DI TOMBOLO (Padova) - ITALY

Tel. +39 049 9413111 - Fax +39 049 9413311 - E-mail: selco@selcoweld.com - www.selcoweld.com

erklærer herved at den nye maskinen

WU 330

er i samsvar med EU-direktivene:

2014/35/EU

LOW VOLTAGE DIRECTIVE

2014/30/EU

EMC DIRECTIVE

2011/65/EU

RoHS DIRECTIVE

og at følgende lovforskrifter er benyttet:

EN 60974-2:2014

EN 60974-10:2015 Class A

Ethvert inngrep eller forandring som ikke er autorisert av **SELCO s.r.l.** ugyldiggjør denne erklæringen. Maskinen er CE market.

Onara di Tombolo (PADOVA)

Selco s.r.l.



Lino Frasson
Chief Executive

INNHOLDSFORTEGNELSE

1 ADVARSEL	59
1.1 Bruksmiljø.....	59
1.2 Personlig beskyttelse og beskyttelse av tredje mann.....	59
1.3 Vern mot elektrisk støt	59
1.4 Elektromagnetiske felt og forstyrrelser.....	59
1.5 Vernegrad IP	60
1.6 Kjølevæske.....	60
1.6.1 Personvern.....	60
1.6.2 Sjøppelhåndtering.....	60
2 INSTALLASJON.....	60
2.1 Løfting, transport og lossing.....	60
2.2 Plassering av anlegget.....	60
2.3 Tilkopling	60
2.4 Installasjon	61
3 PRESENTASJON AV ANLEGGET	61
3.1 Frontpanel	61
4 VEDLIKEHOLD.....	61
5 DIAGNOSTIKK OG LØSNINGER.....	62
6 TEKNISKE SPESIFIKASJONER.....	62

SYMBOLNES FORKLARING



Store farer som forårsaker alvorlige skader på personer og farlig oppførsel som kan føre til alvorlige skader



Viktig råd for å unngå mindre skader på personer eller gjenstander



Tekniske merknader for å lette operasjonene

1 ADVARSEL



Før du bruker maskinen må du forsikre deg om å ha lest og forstått denne håndboka ordentlig.

Utfør ikke modifikasjoner eller vedlikeholdsarbeid som ikke er beskrevet.

Produsenten er ikke ansvarlig for skader på personer eller ting som oppstår på grunn av feil bruk eller manglende utførelse av instruksjonene i denne håndboka.



Ved tvil og problemer om bruken av anlegget, skal du henvende deg til kvalifisert personell.



1.1 Bruksmiljø

- Alt utstyr skal kun brukes for operasjoner som det er prosjektert til, på den måte og i områdene som er angitt på skiltet og/eller i denne håndboka, i samsvar med nasjonale og internasjonale direktiver om sikkerhet. Bruk som skiller seg fra bruksmønstret angitt av fabrikanten er ikke egnet og kan være farlig; i et slikt tilfelle frasier fabrikanten seg alt ansvar.
- Dette apparatet må brukes kun i profesjonelle applikasjoner i industrimiljøer.
Fabrikanten er ikke ansvarlig for skader som beror på privat bruk av anlegget.
- Anlegget skal brukes i miljøer med en temperatur mellom -10°C og $+40^{\circ}\text{C}$ (mellom $+14^{\circ}\text{F}$ og $+104^{\circ}\text{F}$).
Anlegget skal transporteres og oppbevares i miljøer med en temperatur mellom -25°C og $+55^{\circ}\text{C}$ (mellom -13°F og 131°F).
- Anlegget skal brukes i miljøer fritt for støv, syre, gass eller andre etsende stoffer.
- Anlegget må ikke brukes i miljøer med en luftfuktighet over 50% ved 40°C (104°F).
Anlegget må ikke brukes i miljøer med en luftfuktighet over 90% ved 20°C (68°F).
- Anlegget må ikke brukes høyere enn 2000m over havet.

1.2 Personlig beskyttelse og beskyttelse av tredje mann



Forsikre deg om at avkjølingsenheten er slått av før du frakopler slanger for tilførsel og retur av kjølevæsken. Den varme væsken som kommer ut kan føre til alvorlige forbrenninger eller skålding.



Forsikre deg om at det finnes et førstehjelpskrin i nærheten.
Ikke undervurder forbrenninger eller sår.



Før du forlater arbeidsplassen, skal du forsikre deg om at området er sikkert for å unngå ulykker som fører til skade på utstyr eller personer.



1.3 Vern mot elektrisk støt

- Et elektrisk støt kan være dødelig.
- Unngå å røre ved innvendige eller utvendige deler som er forsynt med strøm i sveise- og skjæreanlegget mens anlegget er slått på (sveisebrenner, tenger, jordledninger, elektroder, ledninger, ruller og spoler er elektrisk koplet til sveisekretsen).
- Forsikre deg om at anleggets og operatørens elektriske isolering er korrekt ved å bruke tørre steder og gulv som skal være tilstrekkelig isolert fra jord.



1.4 Elektromagnetiske felt og forstyrrelser

EMC utstyrsklassifisering i overensstemmelse med EN/IEC 60974-10 (Se klassifiseringsmerke eller tekniske data)

Utstyr klasse B er i overensstemmelse med elektromagnetiske kompatibilitetskrav i industriell og beboelsesmiljø, inkludert boligområder hvor den elektriske kraft er forsynt fra det offentlige lavspennings forsyningssystem.

Utstyr klasse A er ikke ment for bruk i boligområder hvor den elektriske kraft er forsynt fra det offentlige lavspennings forsyningssystem. Det kan være potesielle vanskeligheter i å sikre elektromagnetisk kompatibilitet av utstyr klasse A i disse områder, på grunn av styrte såvel som utstrålte forstyrrelser.

Installasjon, bruk og vurdering av området

Dette apparatet er konstruert i samsvar med kravene i den harmoniserte normen EN60974-10 og er identifisert som "KLASSE A".

Denne enheten må brukes kun i profesjonelle applikasjoner i industrimiljøer.

Fabrikanten er ikke ansvarlig for skader som er forårsaket ved bruk av anlegget hjemme.



Brukeren må ha erfaringer i sektoren og er således ansvarlig for installasjonen og bruken av enheten i overensstemmelse med fabrikantens anvisninger.

Hvis elektromagnetiske forstyrrelser oppstår, er det brukeren som må løse problemet, om nødvendig ved hjelp av fabrikantens tekniske assistanse.

Uansett må de elektromagnetiske forstyrrelsene bli redusert slik at de ikke utgjør et problem lenger.



Før du installerer denne enheten, må du ta i betraktning mulige elektromagnetiske problemer som kan oppstå i området og som kan være farlige for personene som er området, f.eks. personer som bruker pace-maker eller høreapparater.

Skjerming

Skjerming av andre kabler og apparater i nærheten kan redusere problemer grunnet elektromagnetiske forstyrrelser. Skjerming av hele sveiseanlegget (skjæring) kan være nødvendig for spesielle applikasjoner.



1.5 Vernegrad IP

IP23S

- Innhold som er beskyttet mot tilgang til farlige deler med fingrene og innføring av massive fremmedlegemer med en diameter som overstiger/er lik 12,5 mm.
- Innholdet er beskyttet mot regn i en vinkel på 60°.
- Innholdet er beskyttet mot skadelige effekter grunnet inntrenging av vann, når apparatets bevegelige deler ikke er igang.



1.6 Kjølevæske

1.6.1 Personvern



Produktet er farlig å få i seg og kan føre til irritasjoner i øynene, slimhinnene og huden.



Unngå all kontakt ved å bruke gummihansker.



Unngå sprut ved å bruke vernebriller.



Unngå kontakt med huden ved å bruke vanlige arbeidsklær.

1.6.2 Sjøppelhåndtering



Eventuelle lekkasjer eller produktrester etter bruk, må behandles i eget renseanlegg eller, hvis mulig, resirkuleres. Det er ikke tillatt å kaste brukte produkter i vassdrag, i grøfter eller dreneringssystemer.

Uttynnet væsker må ikke tømmes i kloakkledningen, hvis dette ikke er tillatt i henhold til lokale forskrifter.

2 INSTALLASJON



Installasjonen skal kun utføres av profesjonelt personale autorisert av fabrikanten.



Under installasjonen skal du forsikre deg om at generatoren er frakoplet.



2.1 Løfting, transport og lossing

- Anlegget er ikke utstyrt med spesifikke deler for løfting.



Ikke undervurder anleggets vekt, (se teknisk spesifikasjon).

Ikke la lasten bevegges eller henges over personer eller ting.



Ikke dropp eller belaste anlegget med unødvendig tyngde.



2.2 Plassering av anlegget

Følg disse reglene:

- Gi lett adgang til kontrollene og kontaktene.
- Plasser ikke utstyret i trange rom.
- Sett aldri anlegget på en flate med en skråning som overstiger 10% fall.
- Plasser anlegget på en tørr, ren plass med tilstrekkelig ventilasjon.
- Beskytt anlegget mot regn og sol.



2.3 Tilkopling

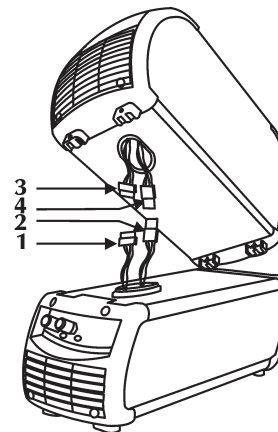

Kjøleenheten er utstyrt med en kontakt 1 for kopling til spenningskilden.

Kjøleenheten er utstyrt med en kontakt 2 for kopling til spenningskilden.



Frakoble spenningen på anlegget før du utfører operasjonene!

- Åpne døren nede på generatoren ved å fjerne de to skruene.
- Kople stikkkontakten 1 på kjøleanlegget til hunkontakten 2 på generatoren.
- Kople stikkkontakten 3 på kjøleanlegget til hunkontakten 4 på generatoren.



2.4 Installasjon

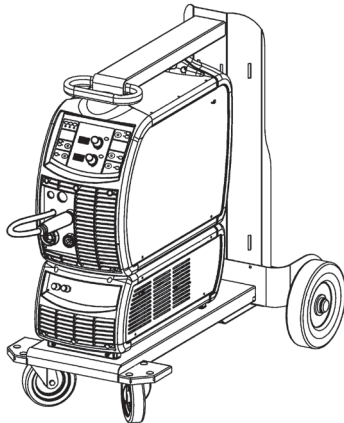



- Plasser WU på GT og fest den med 4 skruer (1).
- Plasser generatoren på kjøleanlegget og fest den med tilhørende skruer.

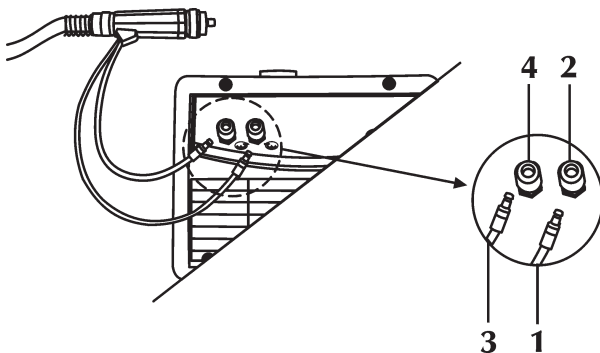

Utfør følgende operasjoner før du slår på enheten:

- Fjern tankens lokk.
- Fjern det hermetiske lokket fra påfyllingskanalen ved å vippe det av med et passende verktøy.
- Fyll kjølevæske på tanken hvis nødvendig.
- Ta vare på forseglingslokket for eventuell framtidig transport av enheten.



- Kople den røde slangen fra brenneren (1) til tilhørende hurtigkople (2) (rød farge - symbol ).
- Kople den blå slangen fra brenneren (3) til tilhørende hurtigkople (4) (blå farge - symbol ).



For å ikke skade kjøleanlegget, skal du alltid montere bypass-slangen når brenneren ikke er koplet til terminalene for inngang/utgang av kjølevæske.



Påfylling eller fylling av tanken skal utføres med kjølevæske kode 18.91.001.

3 PRESENTASJON AV ANLEGGET

3.1 Frontpanel

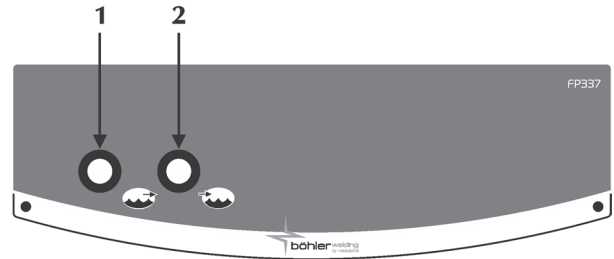

1 Utløpskople for kjølevæske



Kald væske føres inn i sveisebrennerens kjølekrets.

2 Innløpskople for kjølevæske



Væske som har blitt oppvarmet av sveisebrenneren føres inn i WU's interne kjølekrets.

4 VEDLIKEHOLD



Du må utføre normalt vedlikehold på anlegget, i samsvar med fabrikantens instruksjoner.

Ethvert vedlikeholdsarbeid må kun utføres av kvalifisert personell.

Alle adgangsdørene og vedlikeholdsdørene og lokk må være stengt og sitte godt fast når utstyret er igang.

Ikke autoriserte forandringer på systemet er strengt forbudt.

Unngå at det hopper seg opp metallstøv nær eller på selve luf-teribbene.



Kutt strømtilførselen til anlegget før ethvert inngrep!



Kontroller regelmessig nivået på kjølevæsken i tanken. Hvis tanken er helt tom og/eller det er luft i pumpen, kan det forårsake funksjonsfeil på pumpen.

- Kontroller væskevolumet i tanken (2/3 vann og 1/3 kjølevæske).
- Rengjør innvendig med lav trykk komprimert luft og pensler med myk bust.
- Kontroller de elektriske kople og alle koplekabler.
- Kontroller elektropumpens tilstand.
- Kontroller tilstanden i slangekople.

Hver 6. måned skal du skifte ut kjølevæsken og skylle slangene og tanken med vann. Skift ut væsken hvis den koker, da den ved koking taper sine beskyttende egenskaper.



Påfylling eller fylling av kjølevæske i tanken skal utføres med generatorens og WU monterte og plassert på et horisontalt plan.



Påfylling eller etterfylling av tanken skal utføres med kjølevæske kode 18.91.001.

Utstyret må ikke bli brukt uten kjølevæske.



Bruk ikke ledende kjølevæsker.

Hvis ovenstående vedlikeholdsarbeide ikke blir utført, blir garantien erklært ugyldig og fabrikanten fritas alt ansvar.

5 DIAGNOSTIKK OG LØSNINGER



Eventuelle reparasjoner eller utskiftinger av anleggets deler må kun utføres av kvalifisert teknisk personell.

Reparasjonen eller utskiftingen av anleggets deler av personell som ikke er autorisert, betyr en umiddelbar annullering av produktets garanti.

Anlegget må ikke utsettes for endringer av noen type.

Hvis operatøren ikke følger disse instruksjoner, frasier fabrikanten seg alt ansvar.

Mangel på gjennomstrømning i kretsen

Årsak Mangel på væske i tanken.

Løsning Etterfyll.

Årsak Luft i kjølesystemet.

Løsning Kople forbi til utløpstilkoplingen  (blå farve) og luft hydraulikkretsen. La kjølevæskens strømme i noen få sekunder.

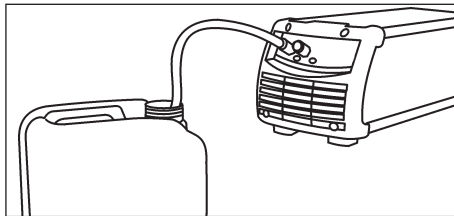

Årsak Kjølekretsen blokkert eller brutt.

Løsning Kontroller tilstanden på tilkoplingene (inne i enheten) på hydraulikkretsen.
Kontroller tilstanden på brennerens hydraulikkrets.
Kontroller tilstanden av kjølekretsen i kabelbunten.
Henvend deg til det nærmeste senter for teknisk assistanse for å reparere anlegget.

Årsak Alarm utløst på kjøleenheten.

Løsning Resett alarmen.
Tilkople en brenner eller forbikople i en operasjonsmodus som krever at kjøleenheten er aktiv.
Kontroller tilstanden på tilkoplingene (inne i enheten) på hydraulikkretsen.
Kontroller tilstanden på brennerens hydraulikkrets.
Henvend deg til det nærmeste senter for teknisk assistanse for å reparere anlegget.

Årsak Defekt pumpe.

Løsning Skift ut den skadde komponenten.
Henvend deg til det nærmeste senter for teknisk assistanse for å reparere anlegget.

Utilfredsstillende kjølekapasitet

Årsak Defekt pumpe.

Løsning Skift ut den skadde komponenten.
Henvend deg til det nærmeste senter for teknisk assistanse for å reparere anlegget.

Årsak Defekt pumpe.

Løsning Skift ut den skadde komponenten.
Henvend deg til det nærmeste senter for teknisk assistanse for å reparere anlegget.

6 TEKNISKE SPESIFIKASJONER

WU 330	
Strømforsyningsspenning U1	1x400 V
Strømforbruk I1 max	0.5 A
Avkjølingseffekt (25°C)	1.0 Kw
Utvekslertype	H2O - Luft
Nominal kapasitet (QV)	2.3 l/min
Maks. kapasitet (Qvmax)	4.6 l/min
Pumpeutbredelse (Hmax)	35 m
Pumpetype	Roterende
Maks. turtall	2900 min
Beskyttelsesgrad IP	IP23S
Tankens kapasitet	5.5 l
Mål (lxdxh)	705x305x250 mm
Vekt	15.0 Kg.
Produksjonsnormer	EN 60974-2/EN 60974-10

YHDENMUKAISUUSILMOITUS CE

Yritys

SELCO s.r.l. - Via Palladio, 19 - 35019 ONARA DI TOMBOLO (Padova) - ITALY
Tel. +39 049 9413111 - Fax +39 049 9413311 - E-mail: selco@selcoweld.com - www.selcoweld.com

ilmoittaa, että laite tyyppiä

WU 330

on seuraavien EU-direktiivien mukainen:

2014/35/EU LOW VOLTAGE DIRECTIVE
2014/30/EU EMC DIRECTIVE
2011/65/EU RoHS DIRECTIVE

ja, että seuraavia normeja on sovellettu:

EN 60974-2:2014
EN 60974-10:2015 Class A

Jokainen korjaus tai muutos ilman **SELCO s.r.l.**:n antamaa lupaa tekee tästä ilmoituksesta pätemättömän.

Onara di Tombolo (PADOVA)

Selco s.r.l.



Lino Frasson
Chief Executive

SISÄLLYS

1 VAROITUS	65
1.1 Työskentelytila	65
1.2 Käyttäjän ja ulkopuolisten henkilöiden suojaaminen	65
1.3 Suojaus sähköiskulta	65
1.4 Sähkömagneettiset kentät ja häiriöt.....	65
1.5 IP-luokitus.....	66
1.6 Jäähdytysneste	66
1.6.1 Henkilöturvallisuus.....	66
1.6.2 Hävittäminen.....	66
2 ASENNUS.....	66
2.1 Nosto, kuljetus ja purkaus.....	66
2.2 Laitteen sijoitus.....	66
2.3 Kytkenä	66
2.4 Käyttöönotto.....	67
3 LAITTEEN ESITTELY	67
3.1 Etuohjauspaneeli.....	67
4 HUOLTO.....	67
5 VIANMÄÄRITYS JA RATKAISUT	68
6 TEKNISET OMINAISUUDET	68

SYMBOLIT



Välitön vakava hengenvaara tai vaarallinen toiminta, joka voi aiheuttaa vakavan ruumiinvamman



Tärkeä neuvo, jota noudattamalla vältetään vähäiset vammat tai omaisuusvahingot



Huomautukset tämän symbolin jälkeen ovat pääosin teknisiä ja helpottavat työskentelyä

1 VAROITUS



Ennen työskentelyä laitteella, varmista että olet lue-
nut ja ymmärtänyt tämän käyttöohjeen sisällön.
Älä tee muutoksia tai huoltotoimenpiteitä, joita ei
ole kuvattu tässä ohjeessa.

Valmistajaa ei voida pitää syyllisenä henkilö- tai
omaisuusvahinkoihin, jotka aiheutuvat tämän materiaalin huoli-
mattomasta lukemisesta tai virheellisestä soveltamisesta.



Käänny ammattitaitoisen henkilön puoleen epäsel-
vissä tapauksissa sekä koneen käyttöön liittyvissä
ongelmissa, myös sellaisissa tapauksissa, joihin näis-
sä ohjeissa ei ole viitattu.



1.1 Työskentelytila

- Kaikkia laitteita tulee käyttää ainoastaan siihen käyttöön,
mihin ne on tarkoitettu, niiden arvokilvessä ja/tai tässä käyttö-
oppaassa olevien ohjeiden mukaisesti, noudattaen kansallisia
ja kansainvälisiä turvallisuusdirektiivejä. Kaikki muu käyttö
katsotaan sopimattomaksi ja vaaralliseksi, eikä valmistaja vas-
taa virheellisestä käytöstä johtuvista vahingoista.
- Tämä laite on suunniteltu vain ammattimaiseen käyttöön
teollisessa ympäristössä.
Valmistaja ei vastaa vahingoista, jotka ovat aiheutuneet siitä,
että laitetta on käytetty kotitaloudessa.
- Laitetta tulee käyttää tiloissa, joiden lämpötila on -10°C ja
 $+40^{\circ}\text{C}$ välillä ($+14^{\circ}\text{F}$... $+104^{\circ}\text{F}$).
Laitetta tulee kuljettaa ja varastoida tiloissa, joiden lämpötila
on -25°C ja $+55^{\circ}\text{C}$ välillä (-13°F ... 131°F).
- Laitetta ei saa käyttää tiloissa, joissa on pölyä, happoja, kaasus-
ja tai muita syövyttäviä aineita.
- Laitetta ei saa käyttää tiloissa, joiden suhteellinen kosteus on
yli 50%, 40°C :ssa (104°F).
Laitetta ei saa käyttää tiloissa, joiden suhteellinen kosteus on
yli 90%, 20°C :ssa (68°F).
- Laitetta tulee käyttää korkeintaan 2000m (6500 jalkaa)
merenpinnan yläpuolella.

1.2 Käyttäjän ja ulkopuolisten henkilöiden suo- jaaminen



Tarkista, että jäähdytysyksikkö on sammutettu ennen
kuin irrotat jäähdytysnesteen syöttö- ja takaisinvirtaus-
letkut. Ulostuleva kuuma neste voi aiheuttaa
vakavia palovammoja tai -haavoja.



Pidä ensiapupakkaus aina lähetyvillä.
Älä aliarvioi palovammojen tai muiden loukkaantu-
misten mahdollisuutta.



Ennen kuin poistut työpaikalta, varmista työskente-
lyalueen turvallisuus henkilö- ja esinevahinkojen
välttämiseksi.



1.3 Suojaus sähköiskulta

- Sähköisku voi johtaa kuolemaan.
- Älä koske hitsaus-/leikkauslaitteen sisä- tai ulkopuolella olevia
jännitteisiä osia laitteen ollessa virtalähteeseen kytkettynä
(polttimet, pihdit, maadoituskaapelit, elektrodit, rullat ja kelat
on kytketty sähköisesti hitsauspiiriin).
- Varmista hitsauslaitteen ja sen käyttäjän sähköinen eristys
käyttämällä tasoja ja alustoja, jotka on riittävästi eristetty
potentiaalista maan ja maadoituksen suhteen.



1.4 Sähkömagneettiset kentät ja häiriöt

EMC-laiteluokitus standardin EN/IEC 60974-10 mukaisesti
(Ks. arvokilpi tai tekniset tiedot)

Luokan B laite täyttää sähkömagneettisen yhteensopivuuden
vaatimukset teollisuus- ja asuinympäristössä, mukaan lukien
asuintalot, joissa sähkönjakelu tapahtuu julkisen matalajännite-
verkon kautta.

Luokan C laitetta ei ole tarkoitettu käytettäväksi asuintaloissa,
joissa sähkönjakelu tapahtuu julkisen matalajänniteverkon kaut-
ta. Luokan A laitteiden sähkömagneettisen yhteensopivuuden
saavuttaminen voi olla vaikeaa näissä olosuhteissa johtuvien ja
säteilievien häiriöiden takia.

Asennus, käyttö ja alueen tarkistus

Tämä laite on valmistettu yhdenmukaistettua standardia
EN60974-10 noudattaen ja on luokiteltu "A LUOKKAAN".

Tämä laite on suunniteltu vain ammattimaiseen käyttöön teolli-
sessa ympäristössä.

Valmistaja ei vastaa vahingoista, jotka ovat aiheutuneet siitä, että
laitetta on käytetty kotitaloudessa.



Laitteen käyttäjän tulee olla alan ammattilainen,
joka on vastuussa laitteen asennuksesta ja sen käy-
töstä valmistajan ohjeita noudattaen. Jos sähkömag-
neettisia häiriöitä havaitaan, käyttäjän on ratkaista-
va ongelma, tarvittaessa yhdessä valmistajan tekni-
sen tuen kanssa.



Kaikissa tapauksissa sähkömagneettisia häiriöitä on
vaimennettava niin paljon, etteivät ne enää aiheuta
haittaa.



Ennen laitteen asennusta käyttäjän on arvioitava
sähkömagneettiset ongelmat, jotka mahdollisesti
voivat tulla esiin lähiympäristössä, keskittyen erityi-
sesti henkilöiden terveydentilaan, esimerkiksi hen-
kilöiden, joilla on sydäntahdistin tai kuulokoje.

Suojaus

Ympäristön muiden kaapeleiden ja laitteistojen valikoiva suoja-
us voi vähentää häiriöongelmia.

Koko hitsaus(leikkaus)laitteiston suojaus voidaan ottaa huomi-
oon erikoissovellutuksissa.

S 1.5 IP-luokitus

IP23S

- Kotelo on suojattu läpimitoiltaan 12,5 mm tai suurempien kiintoaineiden läpitemuutumiselta, ja vaaralliset osat on kosketussuojattu sormilta.
- Kotelointi suojaa roiskevedeltä joka suuntautuu 60° kulmassa pystysuunnasta.
- Kotelointi suojaa sellaisia vaurioita vastaan, jotka aiheuttaa veden sisään pääsy laitteiston liikkuvien osien ollessa liikkeessä.

1.6 Jäähdytysneste

1.6.1 Henkilöturvallisuus



Tuote on myrkyllistä nieltynä. Voi ärsyttää silmiä, limakalvoja ja ihoa.



Kädet suojattava käyttämällä kumisia suojakäsineitä.



Silmät suojattava roiskeilta käyttämällä suojalaseja.



Ihokosketus estettävä suojavaatetusta käyttämällä.

1.6.2 Hävittäminen



Kun tuotetta on käytetty sen normaalitarkoitukseen, tulee päästöt tai jätteet käsitellä käyttöön soveltuvassa puhdistuslaitteessa, tai mikäli mahdollista, kierrättää tuote. Ei saa päästää vesistöön, maaperään tai viemäriin. Laimennettua nestettä ei saa päästää viemäristöön muuten kuin paikallisen vesilaitoksen säännösten ja lupaehtojen mukaisesti.

2 ASENNUS



Ainoastaan valmistajan valtuuttama henkilöstö saa suorittaa asennuksen.



Varmista asennuksen aikana, että generaattori on irti syöttöverkosta.



2.1 Nosto, kuljetus ja purkaus

- Laitteessa ei ole erityisiä nosto-osia.



Älä koskaan aliarvioi laitteen painoa, katso kohta Tekniset ominaisuudet.

Älä koskaan kuljeta laitetta tai jätä sitä roikkumaan niin, että sen alla on ihmisiä tai esineitä.



Älä anna laitteen kaatua äläkä pudota voimalla.



2.2 Laitteen sijoitus

Noudata seuraavia sääntöjä:

- Varmista helppo pääsy laitteen säätöihin ja liitäntöihin.
- Älä sijoita laitetta ahtaaseen paikkaan.
- Älä aseta laitetta vaakasuoralle tasolle tai tasolle, jonka kaltevuus on yli 10°.
- Kytke laitteisto kuivaan ja puhtaaseen tilaan, jossa on sopiva ilmasto.
- Suojaa kone sateelta ja auringolta.



2.3 Kytkeä

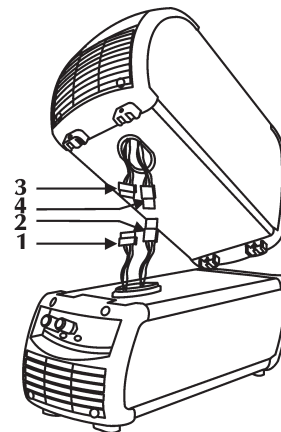

Jäähdytysyksikkö on varustettu liittimellä 1 hitsauskoneeseen liitäntää varten.

Jäähdytysyksikkö on varustettu liittimellä 2 hitsauskoneeseen liitäntää varten.



Irrota laite sähköverkosta aina ennen toimenpiteitä!

- Avaa generaattorin alasuojuksen luukku ja poista kaksi ruuvia.
- Kytke jäähdytysyksikön urosliitin 1 generaattorin naarasliittimeen 2.
- Kytke jäähdytysyksikön urosliitin 3 generaattorin naarasliittimeen 4.



2.4 Käyttöönotto

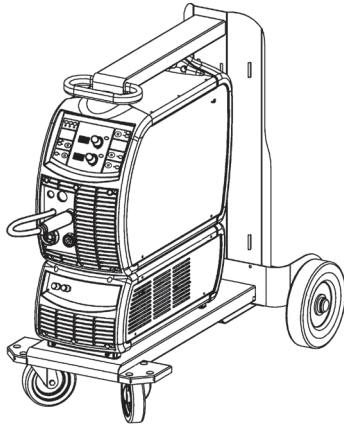



- Aseta WU GT:n päälle ja kiinnitä 4:n ruuvien avulla (1).
- Aseta generaattori jäähdytysyksikön päälle ja kiinnitä ruuveilla.

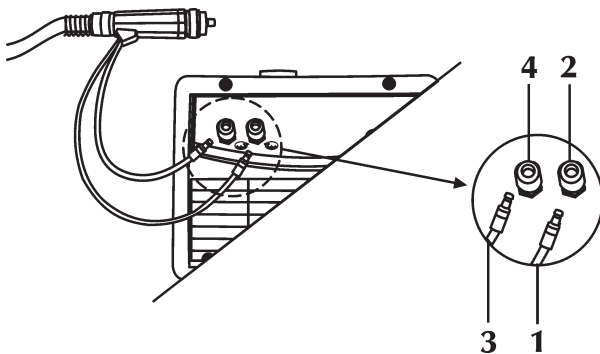

Ennen yksikön käynnistämistä suorita seuraavat toimenpiteet:

- Poista säiliön korkki.
- Irrota sisääntulokanavan hermeettinen korkki sen reunassa olevalla työkalulla.
- Lisää säiliöön tarvittaessa nestettä.
- Säilytä hermeettinen korkki mahdollisia tulevaisuudessa tapahtuvia kuljetuksia varten.



- Kiinnitä polttimen jäähdytysaineen takaisinvirtausletku (1) (punainen) liitäntään/kytkentään (2) (punainen - symboli .
- Kiinnitä polttimen jäähdytysaineen syöttöletku (3) (sininen) liitäntään/kytkentään (4) (sininen - symboli .



Jotta et vahingoittaisi jäähdytysyksikköä asenna aina ohitusputki, kun poltinta ei ole kytketty jäähdytysnesteen sisäänmeno-/ulostuloliittimiin.

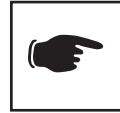

Säiliön täyttöön käytetään jäähdytysnestettä, tilausnumero 18.91.001.

3 LAITTEEN ESITTELY

3.1 Etuohjauspaneeli

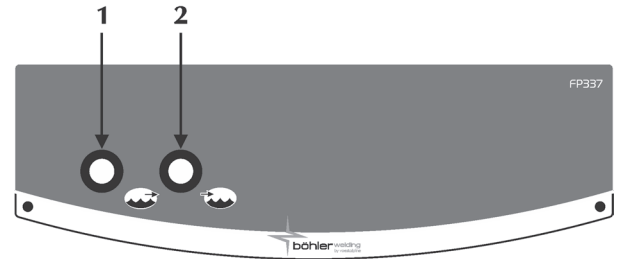

1 Jäähdytysnesteen ulostuloliitin



Viileän nesteen syöttö polttimen jäähdytysjärjestelmään.

2 Jäähdytysnesteen sisääntuloliitin



Polttimen lämmittämän nesteen syöttö WU:n sisäiseen jäähdytysjärjestelmään.

4 HUOLTO



Laitteessa tulee suorittaa normaalihuolto valmistajan antamien ohjeiden mukaisesti.

Huoltotoimia voi tehdä vain niihin pätevyitynyt henkilö. Kun laite on toimiva, kaikki laitteen suojapellit ja luukut on suljettava.

Laitteessa ei saa suorittaa minkäänlaisia muutoksia.

Estä metallipölyä kasaantumasta lähelle tuuletusaukkoja tai niiden päälle.



Irrota laite sähköverkosta ennen huoltotoimenpiteitä.



Jäähdytysnesteen taso säiliössä on tarkistettava säännöllisesti. Säiliön täydellinen tyhjentyminen ja/tai pumpussa oleva ilma voivat estää pumpun käynnistyksen.

- Tarkista nesteen määrä säiliössä (2/3 vettä ja 1/3 jäätyminenestettä).
- Puhdista virtalähde sisältä matalapaineisella paineilmasuihkulla ja pehmeällä harjalla.
- Tarkista sähköiset kytkennät ja kytkentäkaapelit.
- Tarkista sähköpumpun kunto.
- Tarkista putkien liitännät.

Kuuden kuukauden välein on vaihdettava jäähdytysneste sekä huuhdeltava putket ja säiliö vedellä. Jäähdytysneste tulee vaihtaa, jos se on kiehuva, sillä silloin se menettää metalliset suojaominaisuudet.



Jäähdytysnestesäiliön täyttö suoritetaan generaattorin ja WU:n ollessa asennettuina ja vaaka-tasoiselle alustalle asetettuina.



Säiliön täyttöön käytetään jäähdytysnestettä, tilausnumero 18.91.001.

Laitteistoa ei saa käyttää ilman jäähdytysnestettä.



Älä käytä johtavia jäähdytysnesteitä.

Ellei huoltoa suoriteta, kaikkien takuiden voimassaolo lakkaa eikä valmistaja vastaa aiheutuneista vahingoista.

5 VIANMÄÄRITYS JA RATKAISUT



Ainoastaan ammattitaitoiset teknikit saavat suorittaa laitteen mahdolliset korjaus- tai osien vaihtotoimenpiteet.

Takuun voimassaolo lakkaa, mikäli valtuuttamattomat henkilöt ovat suorittaneet laitteen korjaus- tai osien vaihtotoimenpiteitä.

Laitteeseen ei saa tehdä minkäänlaisia muutoksia.

Valmistaja ei vastaa vahingoista, jotka ovat aiheutuneet siitä, ettei ylläolevia ohjeita ole noudatettu.

Neste puuttuu järjestelmästä

Syy Säiliössä ei ole nestettä.

Toimenpide Suorita täydennys.

Syy Ilmaa jäähdytyspiirissä.
Toimenpide Kytke ohitus ulosmenevään liitäntään (sininen) ja ilmaa hydraulipiiri antamalla jäähdytysnesteen virrata ulos muutaman sekunnin ajan.

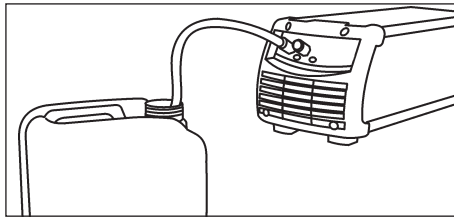

Syy Jäähdytyspiiri tukossa tai rikkoutunut.
Toimenpide Tarkasta hydraulipiirin liitäntöjen kunto (yksikön sisällä).
Tarkasta polttimen hydraulipiirin kunto.
Tarkasta jäähdytyspiirin kunto kaapelipussissa.
Käänny lähimmän huoltokeskuksen puoleen laitteen korjaamista varten.

Syy Hälytys jäähdytysyksiköstä annettu.
Toimenpide Kuittaa hälytys.
Käytä poltinta tai ohitusta toimintatiloissa, jotka vaativat jäähdytysyksikön olevan käynnissä.
Tarkasta hydraulipiirin liitäntöjen kunto (yksikön sisällä).
Tarkasta polttimen hydraulipiirin kunto.
Käänny lähimmän huoltokeskuksen puoleen laitteen korjaamista varten.

Syy Viallinen pumpu.
Toimenpide Vaihda viallinen osa.
Käänny lähimmän huoltokeskuksen puoleen laitteen korjaamista varten.

Riittämätön jäähdytyskapasiteetti

Syy Viallinen tuuletin.

Toimenpide Vaihda viallinen osa.

Käänny lähimmän huoltokeskuksen puoleen laitteen korjaamista varten.

Syy Viallinen pumpu.

Toimenpide Vaihda viallinen osa.

Käänny lähimmän huoltokeskuksen puoleen laitteen korjaamista varten.

6 TEKNISET OMINAISUUDET

	WU 330
Syöttöjännite U1	1x400 V
Ottovirta I1 max	0.5 A
Jäähdytysteho (25°C)	1.0 Kw
Jäähdytintyyppi	H2O - Ilma
Nimellisteho (QV)	2.3 l/min
Suurin teho (Qvmax)	4.6 l/min
Pumpun nostokorkeus (Hmax)	35 m
Pumpun tyyppi	Pyörivä
Maksimi kierrosluku	2900 min
Kotelointiluokka IP	IP23S
Säiliön tilavuus	5.5 l
Mitat (lxsxk)	705x305x250 mm
Paino	15.0 Kg.
Standardit	EN 60974-2/EN 60974-10

ΔΗΛΩΣΗ ΣΥΜΜΟΡΦΩΣΗΣ CE

Η εταιρεία
SELCO s.r.l. - Via Palladio, 19 - 35019 ONARA DI TOMBOLO (Padova) - ITALIA
Tel. +39 049 9413111 - Fax +39 049 9413311 - E-mail: selco@selcoweld.com - www.selcoweld.com

δηλώνει ότι η συσκευή τύπου

WU 330

είναι κατασκευασμένη σε συμμόρφωση με τις Ευρωπαϊκές Οδηγίες:

**2014/35/EU
2014/30/EU
2011/65/EU**

**LOW VOLTAGE DIRECTIVE
EMC DIRECTIVE
RoHS DIRECTIVE**

και ότι έχουν εφαρμοστεί τα πρότυπα:

**EN 60974-2:2014
EN 60974-10:2015 Class A**

Τυχόν επεμβάσεις ή τροποποιήσεις που θα γίνουν χωρίς την εξουσιοδότηση της SELCO s.r.l., θα προκαλέσουν την παύση ισχύος της παραπάνω δήλωσης.

Onara di Tombolo (PADOVA)

Selco s.r.l.



Lino Frasson
Chief Executive

ΠΕΡΙΕΧΟΜΕΝΑ

1 ΠΡΟΕΙΔΟΠΟΙΗΣΕΙΣ	71
1.1 Περιβάλλον χρήσης	71
1.2 Ατομική προστασία και ασφάλεια τρίτων	71
1.4 Ηλεκτρομαγνητικά πεδία και παρεμβολές	71
1.5 Βαθμός προστασίας IP	72
1.6 Υγρό ψύξης	72
1.6.1 Ατομική προστασία	72
1.6.2 Διάθεση απορριμμάτων	72
2 ΕΓΚΑΤΑΣΤΑΣΗ	72
2.1 Τρόπος ανύψωσης, μεταφοράς και εκφόρτωσης	72
2.2 Τοποθέτηση της διάταξης	72
2.3 Σύνδεση	72
2.4 Θέση σε λειτουργία	73
3 ΠΑΡΟΥΣΙΑΣΗ ΤΗΣ ΔΙΑΤΑΞΗΣ	73
3.1 Μπροστινός πίνακας ελέγχου	73
4 ΣΥΝΤΗΡΗΣΗ	73
5 ΔΙΑΓΝΩΣΗ ΠΡΟΒΛΗΜΑΤΩΝ ΚΑΙ ΛΥΣΕΙΣ	74
6 ΤΕΧΝΙΚΑ ΧΑΡΑΚΤΗΡΙΣΤΙΚΑ	74

ΣΥΜΒΟΛΑ



Άμεσοι κίνδυνοι που προκαλούν σοβαρούς τραυματισμούς ή επικίνδυνες ενέργειες που μπορούν να προκαλέσουν σοβαρούς τραυματισμούς



Ενέργειες που μπορούν να προκαλέσουν μη σοβαρούς τραυματισμούς ή βλάβες σε αντικείμενα



Οι σημειώσεις που ακολουθούν αυτό το σύμβολο, έχουν τεχνικό χαρακτήρα και διευκολύνουν τις ενέργειες

1 ΠΡΟΕΙΔΟΠΟΙΗΣΕΙΣ



Πριν προβείτε σε οποιαδήποτε ενέργεια, πρέπει να διαβάσετε και να είστε βέβαιοι ότι κατανοήσατε το παρόν εγχειρίδιο.

Μην κάνετε μετατροπές και ενέργειες συντήρησης που δεν περιγράφονται στο παρόν.

Ο κατασκευαστής δε φέρει καμία ευθύνη για τυχόν βλάβες, σε πρόσωπα ή πράγματα, που οφείλονται σε πλημμελή ανάγνωση και/ή μη εφαρμογή των οδηγιών του παρόντος εγχειριδίου.



Για κάθε αμφιβολία ή πρόβλημα σχετικά με τη χρήση της διάταξης, έστω κι αν δεν περιγράφεται εδώ, συμβουλευτείτε κάποιον εξειδικευμένο τεχνικό.



1.1 Περιβάλλον χρήσης

- Κάθε διάταξη πρέπει να χρησιμοποιείται αποκλειστικά και μόνο για τις λειτουργίες που σχεδιάστηκε, με τους τρόπους και το εύρος τιμών που αναγράφονται στην πινακίδα χαρακτηριστικών και/ή στο παρόν εγχειρίδιο, και σύμφωνα με τους εθνικούς και διεθνείς κανονισμούς ασφαλείας. Οποιαδήποτε άλλη χρήση, που διαφέρει από αυτές που δηλώνει ρητά ο Κατασκευαστής, θεωρείται απολύτως ανάρμοστη και επικίνδυνη, και, στην περίπτωση αυτή, ο Κατασκευαστής δε φέρει καμία ευθύνη.
- Η συσκευή πρέπει να προορίζεται μόνο για επαγγελματική χρήση, σε βιομηχανικό περιβάλλον. Ο κατασκευαστής δε φέρει καμία ευθύνη για βλάβες που ενδεχομένως προκληθούν εξαιτίας της χρήσης της διάταξης μέσα σε κατοικίες.
- Η διάταξη πρέπει να χρησιμοποιείται σε χώρους με θερμοκρασία μεταξύ -10°C και $+40^{\circ}\text{C}$ ($+14^{\circ}\text{F}$ και $+104^{\circ}\text{F}$). Η διάταξη πρέπει να μεταφέρεται και να αποθηκεύεται σε χώρους με θερμοκρασία μεταξύ -25°C και $+55^{\circ}\text{C}$ (-13°F και 131°F).
- Η διάταξη πρέπει να χρησιμοποιείται σε περιβάλλον χωρίς σκόνη, οξέα, αέρια ή άλλες διαβρωτικές ουσίες.
- Η διάταξη πρέπει να χρησιμοποιείται σε περιβάλλον με σχετική υγρασία μικρότερη του 50%, στους 40°C (104°F). Η διάταξη πρέπει να χρησιμοποιείται σε περιβάλλον με σχετική υγρασία μικρότερη του 90%, στους 20°C (68°F).
- Το μέγιστο επιτρεπόμενο υψόμετρο για τη χρήση της διάταξης είναι 2000 μ. (6500 πόδια).

1.2 Ατομική προστασία και ασφάλεια τρίτων



Πριν αποσυνδέσετε τους σωλήνες προσαγωγής και επιστροφής του ψυκτικού υγρού, βεβαιωθείτε ότι η μονάδα ψύξης είναι σβηστή. Το θερμό υγρό που βγαίνει μπορεί να προκαλέσει σοβαρά εγκαύματα.



Προμηθευτείτε τα απαραίτητα μέσα πρώτων βοηθειών. Μην παραμελείτε τυχόν εγκαύματα ή τραυματισμούς.



Πριν εγκαταλείψετε τη θέση εργασίας, πάρτε τα απαραίτητα μέτρα ασφαλείας, για να αποφευχθούν ακούσιες βλάβες και ατυχήματα.



1.3 Προστασία από ηλεκτροπληξία

- Η ηλεκτροπληξία μπορεί να προκαλέσει θάνατο.
- Αποφύγετε την επαφή με τα σημεία που βρίσκονται συνήθως υπό τάση, στο εσωτερικό ή στο εξωτερικό της διάταξης συγκόλλησης/κοπής, όταν η διάταξη έχει ρεύμα (οι τσιμπίδες, τα σώματα γείωσης, τα καλώδια γείωσης, τα ηλεκτρόδια, τα καλώδια, τα ράουλα και τα καρούλια συνδέονται με το ηλεκτρικό κύκλωμα συγκόλλησης).
- Εξασφαλίστε την ηλεκτρική μόνωση της εγκατάστασης συγκόλλησης και του χειριστή, χρησιμοποιώντας στεγνές επιφάνειες και βάσεις, με επαρκή μόνωση από το δυναμικό του εδάφους και της γείωσης.



1.4 Ηλεκτρομαγνητικά πεδία και παρεμβολές

Ταξινόμηση ΗΜΣ της συσκευής, σύμφωνα με το πρότυπο EN/IEC 60974-10 (βλ. πινακίδα αναγνώρισης ή τεχνικά χαρακτηριστικά)

Η συσκευή κατηγορίας Β είναι κατασκευασμένη σε συμμόρφωση με τις απαιτήσεις συμβατότητας σε βιομηχανικούς χώρους ή κατοικίες, συμπεριλαμβανομένων των κατοικημένων περιοχών όπου η ηλεκτρική ενέργεια παρέχεται από κάποιο δημόσιο σύστημα χαμηλής τάσης.

Η συσκευή κατηγορίας Α δεν προορίζεται για χρήση σε κατοικημένες περιοχές όπου η ηλεκτρική ενέργεια παρέχεται από κάποιο δημόσιο σύστημα χαμηλής τάσης. Θα ήταν δύσκολο να εξασφαλιστεί η ηλεκτρομαγνητική συμβατότητα των συσκευών κατηγορίας Α σε αυτές τις περιοχές, εξαιτίας των παρεμβολών που εκπέμπονται και προσάγονται.

Εγκατάσταση, χρήση και αξιολόγηση του χώρου

Η συσκευή αυτή κατασκευάζεται σύμφωνα με τις οδηγίες του εναρμονισμένου προτύπου EN60974-10 και κατατάσσεται στην "ΚΑΤΗΓΟΡΙΑ Α".

Η συσκευή πρέπει να προορίζεται μόνο για επαγγελματική χρήση, σε βιομηχανικό περιβάλλον.

Ο κατασκευαστής δε φέρει καμία ευθύνη για βλάβες που ενδεχομένως προκληθούν εξαιτίας της χρήσης της διάταξης μέσα σε κατοικίες.



Ο χρήστης πρέπει να έχει εμπειρία στον τομέα αυτό και θεωρείται υπεύθυνος για την εγκατάσταση και τη χρήση της συσκευής, σύμφωνα με τις οδηγίες του κατασκευαστή. Αν παρατηρηθούν ηλεκτρομαγνητικές παρεμβολές, ο χρήστης πρέπει να λύσει το πρόβλημα με την τεχνική υποστήριξη του κατασκευαστή.



Σε όλες τις περιπτώσεις, οι ηλεκτρομαγνητικές παρεμβολές πρέπει να ελαττωθούν έως το βαθμό στον οποίο που δεν προκαλούν ενόχληση.



Πριν την εγκατάσταση της συσκευής, ο χρήστης πρέπει να εκτιμήσει τα πιθανά ηλεκτρομαγνητικά προβλήματα που θα μπορούσαν να παρουσιαστούν στη γύρω ζώνη και ιδιαίτερα στην υγεία των παρόντων. Για παράδειγμα: άτομα με pacer-maker και ακουστικά βαρηκοΐας.

Θωράκιση

Η επιλεκτική θωράκιση άλλων καλωδίων και συσκευών στη γύρω περιοχή μπορεί να μειώσει τα προβλήματα παρεμβολών. Σε ειδικές εφαρμογές, θα μπορούσε να ληφθεί υπόψη η θωράκιση όλης της διάταξης συγκόλλησης (κοπής).



1.5 Βαθμός προστασίας IP

IP23S

- Περιβλήμα που αποτρέπει την τυχαία πρόσβαση σε επικίνδυνα μέρη κάποιου δάχτυλου ή κάποιου ξένου σώματος με διάμετρο ίση ή μεγαλύτερη από 12,5 mm.
- Περιβλήμα προστατευμένο από βροχή που πέφτει με γωνία 60°.
- Περιβλήμα που αποτρέπει τις βλαβερές συνέπειες της εισόδου νερού, όταν τα κινούμενα μέρη της συσκευής είναι ακίνητα.



1.6 Υγρό ψύξης

1.6.1 Ατομική προστασία



Βλαβερό σε περίπτωση κατάποσης. Μπορεί να προκαλέσει ερεθισμό στα μάτια, στη βλεννογόνο και στο δέρμα.



Αποφύγετε την επαφή φορώντας λαστιχένια γάντια.



Για να αποφεύγετε τα πιτσιλίσματα, φοράτε προστατευτικά γυαλιά.



Για να αποφύγετε την επαφή με το δέρμα, φοράτε κατάλληλα ρούχα εργασίας.

1.6.2 Διάθεση απορριμμάτων



Οι διαρροές ή τα υπολείμματα του προϊόντος, αφού αυτό έχει χρησιμοποιηθεί με το συνήθη τρόπο, πρέπει να υποβάλλονται σε κατάλληλη επεξεργασία καθαρισμού ή, αν είναι δυνατό, να γίνεται ανακύκλωση του προϊόντος. Δεν επιτρέπεται να διοχετεύετε τα απόβλητα σε ρυάκια, χαντάκια ή υπονόμους. Δεν πρέπει να διοχετεύετε τα αραιωμένα απόβλητα στους υπονόμους, εκτός αν αυτό επιτρέπεται από την τοπική νομοθεσία.

2 ΕΓΚΑΤΑΣΤΑΣΗ



Η εγκατάσταση μπορεί να γίνει μόνο από έμπειρο προσωπικό, εξουσιοδοτημένο από τον κατασκευαστή.



Πριν την εγκατάσταση, βεβαιωθείτε ότι η γεννήτρια είναι αποσυνδεδεμένη από το ηλεκτρικό δίκτυο.



2.1 Τρόπος ανύψωσης, μεταφοράς και εκφόρτωσης

- Η διάταξη δεν διαθέτει ειδικά εξαρτήματα για την ανύψωση.



Μην υποτιμάτε το βάρος της εγκατάστασης (βλ. τεχνικά χαρακτηριστικά).

Κατά την ανύψωση του ζυγιστικού, κανένα άτομο δεν πρέπει να βρίσκεται κάτω από αυτό.



Αποφύγετε την πτώση της διάταξης και μην την αποθέτετε με δύναμη στο δάπεδο.



2.2 Τοποθέτηση της διάταξης

Τηρήστε τους εξής κανόνες:

- Εύκολη πρόσβαση στα όργανα ελέγχου και τις συνδέσεις.
- Μην τοποθετείτε τον εξοπλισμό σε στενούς χώρους.
- Μην τοποθετείτε ποτέ τη διάταξη πάνω σε μια επιφάνεια με κλίση μεγαλύτερη από 10° ως προς το οριζόντιο επίπεδο.
- Τοποθετήστε τη διάταξη σε χώρο στεγνό, καθαρό και με επαρκή εξαερισμό.
- Προστατέψτε τη διάταξη από τη βροχή και τον ήλιο.

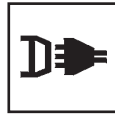

2.3 Σύνδεση

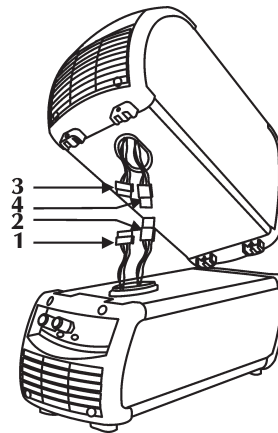

Η μονάδα ψύξης διαθέτει ένα συνδετήρα 1 για τη σύνδεση της μηχανής συγκόλλησης.

Η μονάδα ψύξης διαθέτει ένα συνδετήρα 2 για τη σύνδεση της μηχανής συγκόλλησης.



Διακόπτετε την τροφοδοσία ρεύματος, πριν από κάθε επέμβαση!

- Ανοίξτε τη θυρίδα που υπάρχει στο κάτω κάλυμμα της γεννήτριας, αφαιρώντας τις δύο βίδες.
- Συνδέστε το αρσενικό βύσμα 1 της μονάδας ψύξης στην υποδοχή 2 της γεννήτριας.
- Συνδέστε το αρσενικό βύσμα 3 της μονάδας ψύξης στην υποδοχή 4 της γεννήτριας.



2.4 Θέση σε λειτουργία

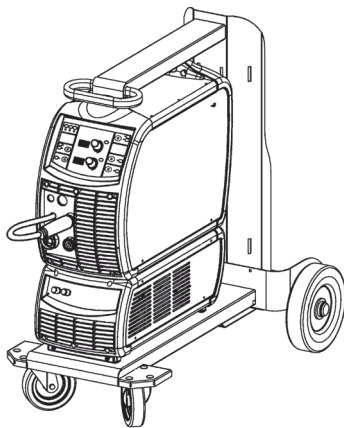



- Τοποθετήστε το WU πάνω στο GT και στερεώστε το με τις κατάλληλες 4 βίδες (1).
- Τοποθετήστε τη γεννήτρια πάνω στη μονάδα ψύξης και στερεώστε την με τις ειδικές βίδες.

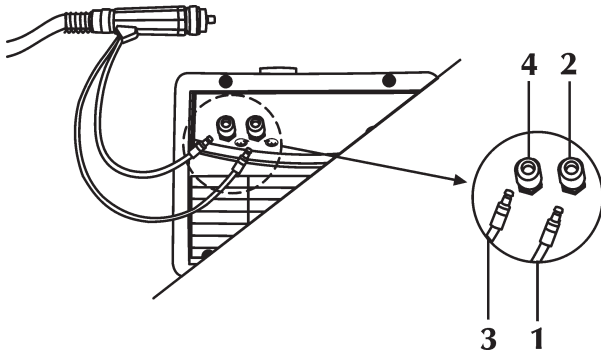

Πριν βάλετε τη μονάδα σε λειτουργία, κάντε τις εξής ενέργειες:

- Αφαιρέστε το πώμα του δοχείου.
- Βγάλτε το ερμητικό πώμα από το στόμιο πλήρωσης, πιέζοντας με ένα εργαλείο στο χείλος του πώματος.
- Αν χρειάζεται, προσθέστε υγρό στο δοχείο.
- Κρατήστε το ερμητικό πώμα για ενδεχόμενες μελλοντικές μεταφορές της μονάδας.



- Συνδέστε το σωλήνα επιστροφής ψυκτικού υγρού της τσιμπίδας (1) (κόκκινου χρώματος), στο ειδικό ρακόρ/σύνδεσμο (2) (κόκκινου χρώματος - σύμβολο )
- Συνδέστε το σωλήνα προσαγωγής ψυκτικού υγρού της τσιμπίδας (3) (μπλε χρώματος), στο ειδικό ρακόρ/σύνδεσμο (4) (μπλε χρώματος - σύμβολο )



Για να μην προκαλέσετε φθορές στη μονάδα ψύξης, ο σωλήνας by-pass πρέπει να μοντάρεται προτού ακόμη συνδεθεί η τσιμπίδα στους ακροδέκτες εισόδου/εξόδου του ψυκτικού υγρού.





Το ψυκτικό υγρό πλήρωσης ή συμπλήρωσης του δοχείου πρέπει να έχει τον κωδ. 18.91.001.

3 ΠΑΡΟΥΣΙΑΣΗ ΤΗΣ ΔΙΑΤΑΞΗΣ

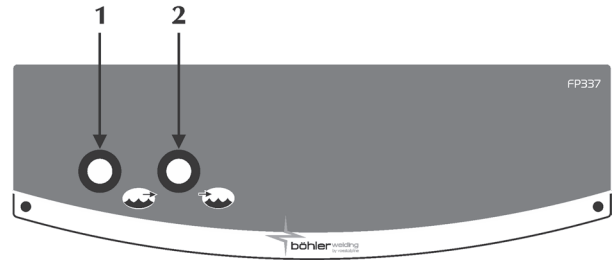
3.1 Μπροστινός πίνακας ελέγχου



- 1 Ρακόρ / σύνδεσμος εξόδου ψυκτικού υγρού**
 Επιτρέπει την εισαγωγή του υγρού με χαμηλή θερμοκρασία στο κύκλωμα ψύξης της τσιμπίδας.
- 2 Ρακόρ / σύνδεσμος εισόδου ψυκτικού υγρού**
 Επιτρέπει την εισαγωγή του υγρού που θερμάνθηκε στην τσιμπίδα, στο εσωτερικό κύκλωμα ψύξης του WU.

4 ΣΥΝΤΗΡΗΣΗ



Η διάταξη πρέπει να συντηρείται τακτική, σύμφωνα με τις οδηγίες του κατασκευαστή.

Η ενδεχόμενη συντήρηση πρέπει να εκτελείται μόνο από εξειδικευμένους τεχνικούς. Όλες οι θυρίδες πρόσβασης και συντήρησης, καθώς και τα καπάκια, πρέπει να είναι κλειστά και καλά στερεωμένα, όταν η συσκευή βρίσκεται σε λειτουργία. Απαγορεύεται οποιαδήποτε μετατροπή της διάταξης. Μην επιτρέψετε τη συσσώρευση μεταλλικής σκόνης γύρω από τα πτερύγια αερισμού.



Διακόπτετε την τροφοδοσία ρεύματος, πριν από κάθε επέμβαση!



Ελέγχετε περιοδικά τη στάθμη του ψυκτικού υγρού στο δοχείο. Το πλήρες άδειασμα του δοχείου και/ή παρουσία αέρα στην αντλία μπορεί να προκαλέσουν προβλήματα στην ομαλή λειτουργία της.

- Ελέγξτε την ποσότητα υγρού στο δοχείο (2/3 νερό και 1/3 αντιψυκτικό υγρό).
- Καθαρίστε το εσωτερικό με πεπιεσμένο αέρα σε χαμηλή πίεση και μαλακό πινέλο.
- Ελέγξτε τις ηλεκτρικές συνδέσεις και όλα τα καλώδια σύνδεσης.
- Ελέγξτε την κατάσταση της ηλεκτραντλίας.
- Ελέγξτε την κατάσταση των συνδέσεων των σωληνών.

Κάθε έξι μήνες, αλλάζετε το ψυκτικό υγρό και ξεβγάζετε τους σωλήνες και το δοχείο με νερό. Αλλάζετε το υγρό σε περίπτωση που βράσει, γιατί χάνει τις μεταλλικές προστατευτικές ιδιότητές του.



Η πλήρωση ή συμπλήρωση του δοχείου με ψυκτικό υγρό πρέπει να γίνεται με τη γεννήτρια και τη μονάδα WU συναρμολογημένες και πάνω σε επίπεδη επιφάνεια.



Το ψυκτικό υγρό πλήρωσης ή συμπλήρωσης του δοχείου πρέπει να έχει τον κωδ. 18.91.001. Η διάταξη δεν πρέπει να χρησιμοποιείτε ποτέ χωρίς ψυκτικό υγρό.

κά υγρά.



Μη χρησιμοποιείτε αγωγή ψυκτικά υγρά.

Σε περίπτωση που δεν γίνεται η συνιστώμενη συντήρηση, παύει η ισχύς όλων των εγγυήσεων και ο κατασκευαστής απαλλάσσεται από οποιαδήποτε ευθύνη.

5 ΔΙΑΓΝΩΣΗ ΠΡΟΒΛΗΜΑΤΩΝ ΚΑΙ ΛΥΣΕΙΣ



Η ενδεχόμενη επισκευή ή αντικατάσταση εξαρτημάτων της διάταξης, πρέπει να γίνεται αποκλειστικά από εξειδικευμένους τεχνικούς.

Η επισκευή ή η αντικατάσταση εξαρτημάτων της διάταξης από μη εξειδικευμένο προσωπικό έχει ως συνέπεια την άμεση ακύρωση της εγγύησης του προϊόντος.

Απαγορεύεται οποιαδήποτε μετατροπή της διάταξης.

Ο κατασκευαστής δεν φέρει καμία ευθύνη, σε περίπτωση που ο χειριστής δε συμμορφωθεί με τις οδηγίες.

Απουσία ροής στο κύκλωμα

Αιτία Απουσία υγρού στο δοχείο.
Λύση Προσθέστε υγρό.

Αιτία Αέρας στο κύκλωμα ψύξης.
Λύση Βάλτε το by-pass στο σύνδεσμο εξόδου (μπλε χρώμα) και εξαερίστε το υδραυλικό κύκλωμα, επιτρέποντας την εκροή του ψυκτικού υγρού για μερικά δευτερόλεπτα.

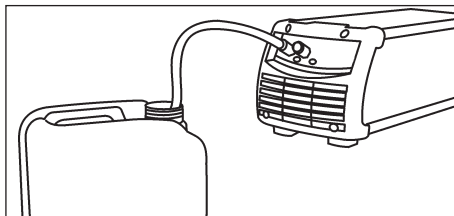

Αιτία Απόφραξη ή διακοπή κυκλώματος ψύξης.
Λύση Ελέγξτε την κατάσταση των συνδέσεων (στο εσωτερικό της μονάδας) του υδραυλικού κυκλώματος.
Ελέγξτε την κατάσταση του υδραυλικού κυκλώματος της τσιμπίδας.
Ελέγξτε την κατάσταση του υδραυλικού κυκλώματος της δέσμης καλωδίων.
Απευθυνθείτε στο πλησιέστερο κέντρο τεχνικής υποστήριξης, για την επισκευή της διάταξης.

Αιτία Παρουσία κατάστασης συναγερμού στη μονάδα ψύξης.

Λύση Εξουδετερώστε τον συναγερμό.
Συνδέστε μία τσιμπίδα ή το by-pass κατά τους τρόπους λειτουργίας όπου προβλέπεται η ενεργοποίηση της μονάδας ψύξης.
Ελέγξτε την κατάσταση των συνδέσεων (στο εσωτερικό της μονάδας) του υδραυλικού κυκλώματος.
Ελέγξτε την κατάσταση του υδραυλικού κυκλώματος της τσιμπίδας.
Απευθυνθείτε στο πλησιέστερο κέντρο τεχνικής υποστήριξης, για την επισκευή της διάταξης.

Αιτία Πρόβλημα στην αντλία.

Λύση Αντικαταστήστε το ελαττωματικό εξάρτημα.
Απευθυνθείτε στο πλησιέστερο κέντρο τεχνικής υποστήριξης, για την επισκευή της διάταξης.

Ανεπαρκής ψυκτική ικανότητα

Αιτία Πρόβλημα στον ανεμιστήρα.

Λύση Αντικαταστήστε το ελαττωματικό εξάρτημα.
Απευθυνθείτε στο πλησιέστερο κέντρο τεχνικής υποστήριξης, για την επισκευή της διάταξης.





Αιτία Πρόβλημα στην αντλία.

Λύση Αντικαταστήστε το ελαττωματικό εξάρτημα.
Απευθυνθείτε στο πλησιέστερο κέντρο τεχνικής υποστήριξης, για την επισκευή της διάταξης.

6 ΤΕΧΝΙΚΑ ΧΑΡΑΚΤΗΡΙΣΤΙΚΑ

WU 330	
Τάση τροφοδοσίας U1	1x400 V
Απορροφούμενο ρεύμα I1 max	0.5 A
Ισχύς ψύξης (25°C)	1.0 Kw
Τύπος εναλλάκτη	H2O - Αέρας
Ονομαστική παροχή (QV)	2.3 l/min
Μέγιστη παροχή (Qvmax)	4.6 l/min
Μανομετρικό ύψος αντλίας (Hmax)	35 m
Τύπος αντλίας	Περιστροφική
Μέγ. αριθμ. στροφών	2900 min
Βαθμός προστασίας IP	IP23S
Χωρητικότητα δοχείου	5.5 l
Διαστάσεις (ΠxΒxΥ)	705x305x250 mm
Βάρος	15.0 Kg.
Πρότυπα κατασκευής	EN 60974-2/EN 60974-10

7 Targa dati, Rating plate, Leistungsschilder, Plaque signalétique, Placa de características, Placa de dados, Technische gegevens, Märkplåt, Dataskilt, Identifikasjonsplate, Arvokilpi, πινακίδα χαρακτηριστικων

		SELCO S.R.L. Via Palladio, 19 - ONARA (PADOVA) - ITALY	
Type WU330		N°	
		EN 60974-2 EN 60974-10 Class A	
Energy input			
	U ₁ = 400V 1 ~ 50 Hz		I _{1max} = 0,5A
	IP 23 S		
Liquid cooling system			
	P _{11/min} = 1,0 kW	P _{max} = 0,35 MPa (3,5 bar)	
CE			



Prodotto europeo
European product
Erzeugt in Europa
Produit européen
Producto Europeo



Non collocare l'apparecchiatura elettrica tra i normali rifiuti!
In osservanza alla Direttiva Europea 2002/96/EC sui Rifiuti di Apparecchiature Elettriche ed Elettroniche e alla sua implementazione in accordo con le leggi nazionali, le apparecchiature elettriche che hanno raggiunto la fine del ciclo di vita devono essere raccolte separatamente e inviate ad un centro di recupero e smaltimento. Il proprietario dell'apparecchiatura dovrà identificare i centri di raccolta autorizzati informandosi presso le Amministrazioni Locali.
L'applicazione della Direttiva Europea permetterà di migliorare l'ambiente e la salute umana.

Do not dispose of electrical equipment together with normal waste!
In observance of European Directive 2002/96/EC on Waste Electrical and Electronic Equipment and its implementation in accordance with national law, electrical equipment that has reached the end of its life must be collected separately and returned to an environmentally compatible recycling facility. As the owner of the equipment, you should get information on approved collection systems from our local representative.
By applying this European Directive you will improve the environment and human health!

Das Elektrogerät nicht in den normalen Hausmüll geben!
Unter Beachtung der Europäischen Richtlinie 2002/96/EC über Elektro- und Elektronikaltgeräte und ihrer Anwendung gemäß den nationalen Gesetzen müssen Elektrogeräte, die am Ende ihrer Lebensdauer angelangt sind, gesondert gesammelt und einer Recycling- und Entsorgungsstelle übergeben werden. Der Eigentümer des Geräts muss sich bei den Örtlichen Verwaltungen über die autorisierten Sammelstellen informieren.
Durch die Einhaltung der Europäischen Richtlinie schützen Sie die Umwelt und die Gesundheit Ihrer Mitmenschen.

Ne pas jeter les équipements électriques avec les déchets ménagers!
En application de la Directive Européenne 2002/96/EC relative aux déchets d'équipements Electriques et Electroniques et de son application conformément aux lois nationales, les équipements électriques à éliminer doivent être jetés séparément et envoyés à un centre de récupération et d'élimination. Le propriétaire de l'appareillage devra s'informer sur les centres de collecte autorisés auprès des Administrations Locales.
L'application de la Directive Européenne permettra de respecter l'environnement et la santé des êtres humains.

iNo arroje nunca el equipo eléctrico entre los residuos comunes!
Respetando la Directiva Europea 2002/96/EC sobre los Residuos de Equipos eléctricos y Electrónicos y su aplicación de acuerdo con las leyes nacionales, los equipos eléctricos que llegaron al final de su ciclo de vida deben recogerse por separado y enviarse a un centro de reciclaje y eliminación. El propietario del equipo deberá identificar los centros de recogida autorizados, informándose en las Administraciones locales.
La aplicación de la Directiva Europea permitirá mejorar el medio ambiente y la salud humana.

8 Significato targa dati del WU, Meaning of WU data plate, Bedeutung der Angaben auf dem Leistungsschild des WU, Signification de la plaque signalétique du WU, Significado de la etiqueta de los datos del WU, Significado da placa de dados do WU, Betekenis van de WU gegevens kaart, Innebörden av uppgifterna på WU-enhetens märkplåt, Betydning af oplysningerne på WU-enhedens dataskilt, Beskrivelse av WU informasjonsskilt, WU kilven sisältö, Σημασία πινακίδας χαρ ακτηριότικών της WU

1		2	
3		4	
		5	
6	7	8	
	9		
10	11	12	
CE			

ITALIANO

- 1 Marchio di fabbricazione
- 2 Nome ed indirizzo del costruttore
- 3 Modello dell'apparecchiatura
- 4 N° di serie
- 5 Riferimento alle norme di costruzione
- 6 Simbolo per l'alimentazione
- 7 Tensione nominale d'alimentazione
- 8 Massima corrente nominale d'alimentazione
- 9 Grado di protezione
- 10 Simbolo per il raffreddamento
- 11 Potenza di raffreddamento
- 12 Pressione massima

ENGLISH

1. Trademark
2. Name and address of manufacturer
3. Machine model
4. Serial no.
5. Reference to construction standards
6. Power supply symbol
7. Rated power supply voltage
8. Maximum rated power supply current
9. Protection rating
10. Cooling system symbol
11. Cooling power
12. Maximum pressure

DEUTSCH

- 1 Marke
- 2 Herstellername und -adresse
- 3 Gerätemodell
- 4 Seriennummer
- 5 Hinweis auf die Konstruktionsnormen
- 6 Symbol der Stromversorgung
- 7 Nennspannung der Stromversorgung
- 8 maximale Nennstromaufnahme
- 9 Schutzart
- 10 Kühlsystem-Symbol
- 11 Kälteleistung
- 12 Höchstdruck

FRANÇAIS

- 1 Marque de fabrication
- 2 Nom et adresse du constructeur
- 3 Modèle de l'appareil
- 4 N° de série
- 5 Référence aux normes de construction
- 6 Symbole pour l'alimentation
- 7 Tension nominale d'alimentation
- 8 Courant maximum nominal d'alimentation
- 9 Degré de protection
- 10 Symbole de refroidissement
- 11 Puissance de refroidissement
- 12 Pression maximum

ESPAÑOL

- 1 Marca de fabricación
- 2 Nombre y dirección del fabricante
- 3 Modelo del aparato
- 4 N° de serie
- 5 Referencia a las normas de construcción
- 6 Símbolo de la alimentación
- 7 Tensión asignada de alimentación
- 8 Máxima corriente asignada de alimentación
- 9 Grado de protección
- 10 Símbolo del sistema de refrigeración
- 11 Potencia de refrigeración
- 12 Presión máxima

9 Schema, Diagram, Schaltplan, Schéma, Esquema, Diagrama, Schema, kopplingschema, Oversigt, Skjema, Kytentäkaavio, Διαγράμμα

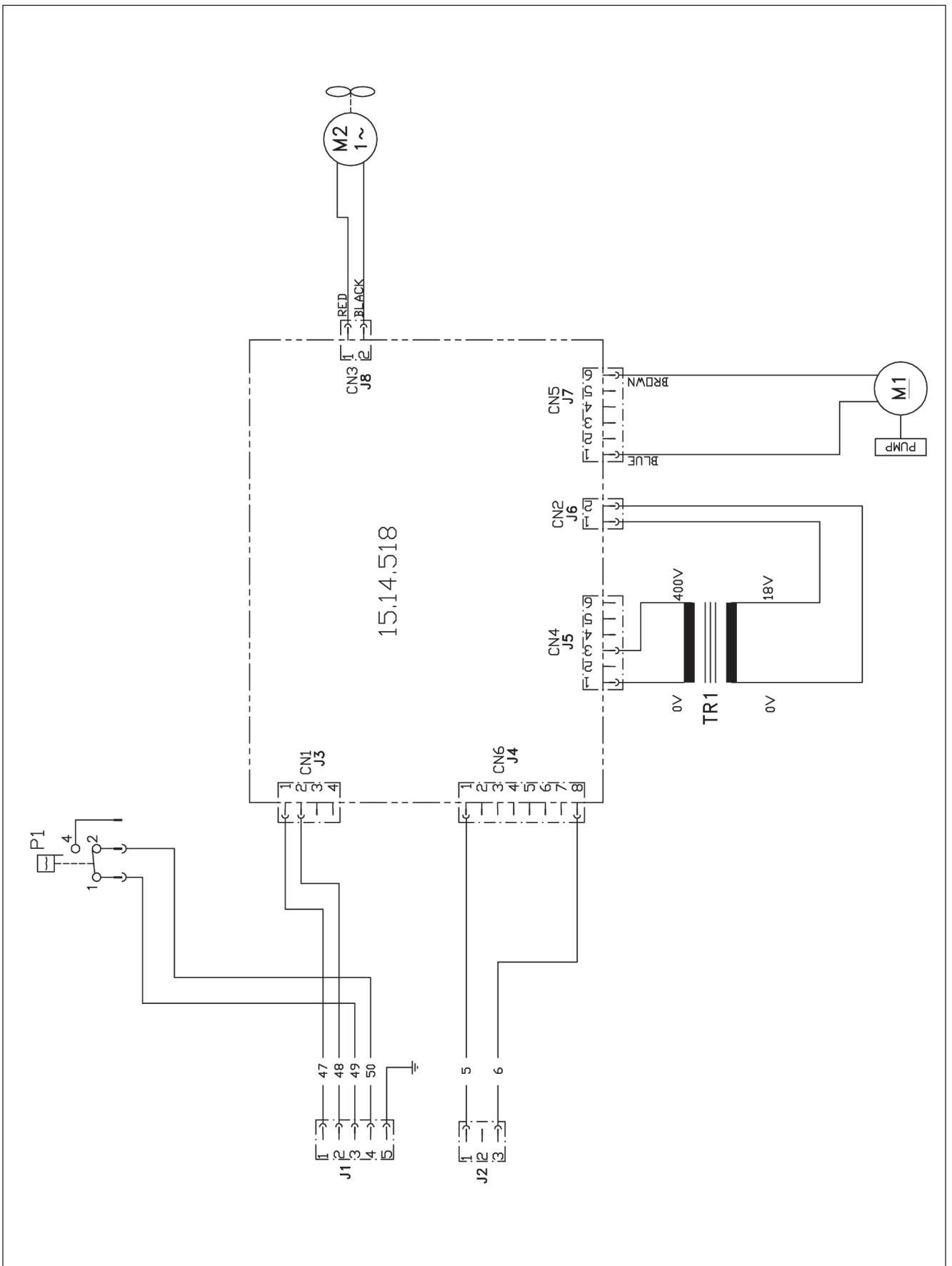

10 Connettori, Connectors, Verbinder, Connecteurs, Conectores, Conectores, Verbindungen, Kontaktdon, Konnektorer, Skjøtemunnstykker, Liittimet, Συνδετηρες

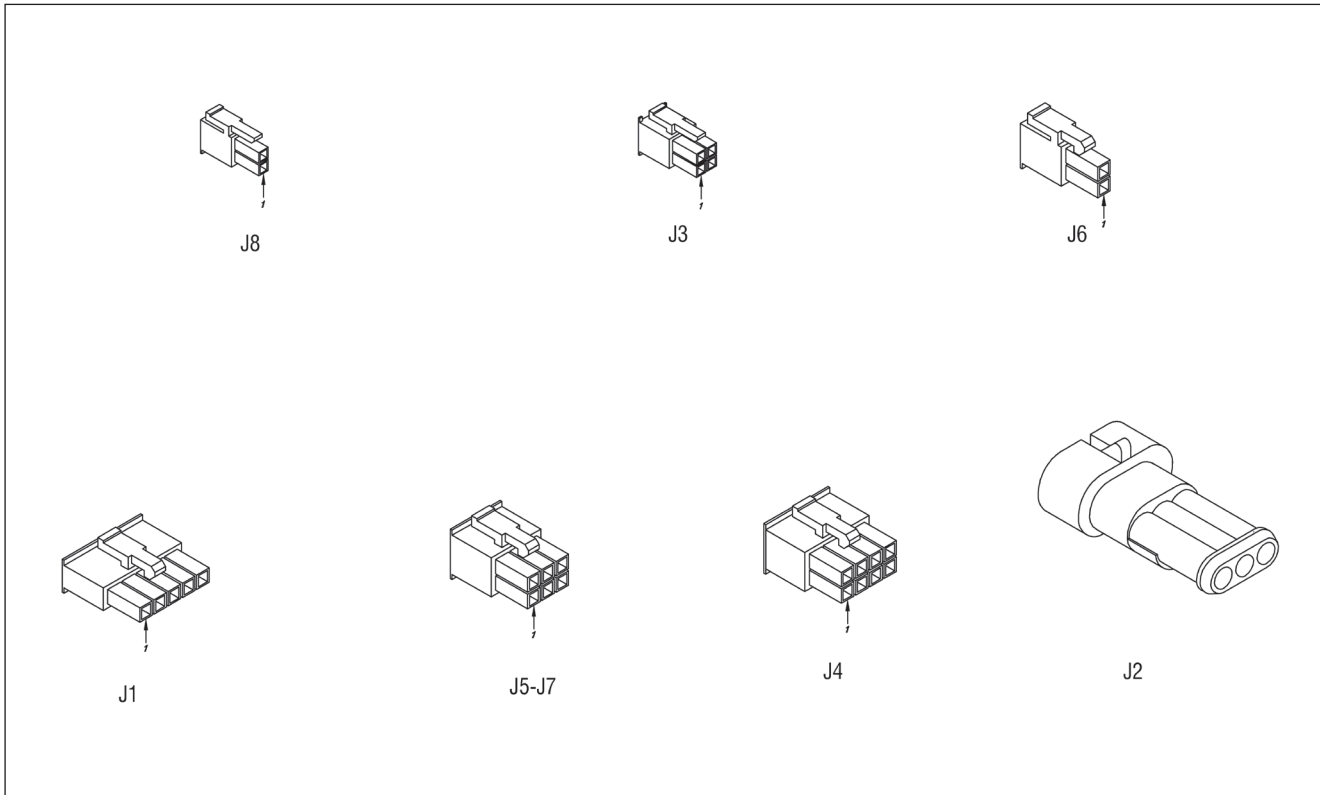

11 Lista ricambi, Spare parts list, Ersatzteilverzeichnis, Liste de pièces détachées, Lista de repuestos, Lista de peças de reposição, Lijst van reserve onderdelen, Reservdelistsa, Reservedelsliste, Liste over reservedeler, Varaosaluettelo, καταλογος ανταλλακτικων

71.03.072 WU 330

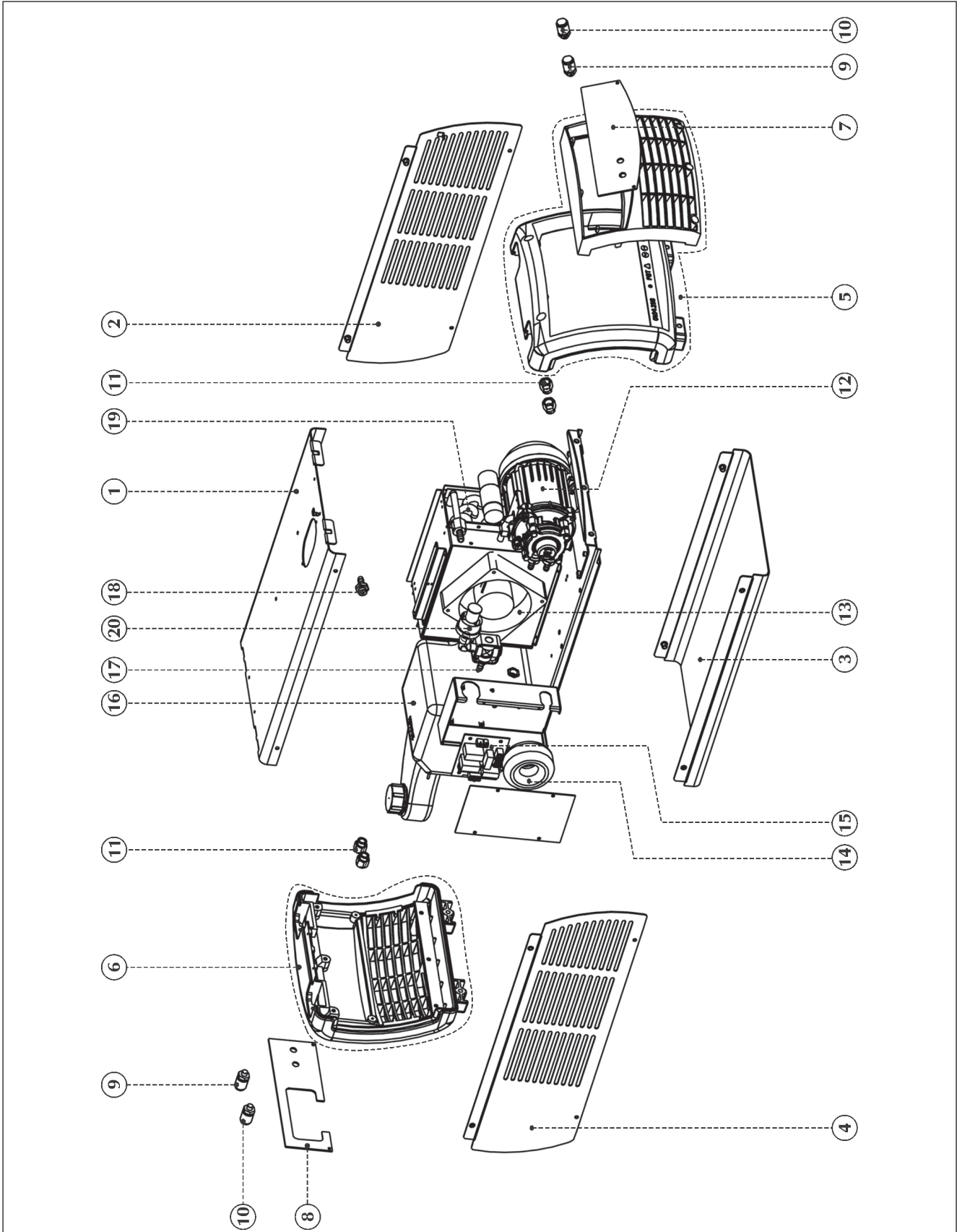

POS. CODE	ITALIANO	ENGLISH	DEUTSCH	FRANÇAIS	ESPAÑOL
1	01.02.12502 Cofano superiore	Wraparound-upper cover (metal)	Oberes gehäuse	Carter supérieur	Chapa superior
2	01.03.05902 Pannello laterale SX	Side panel - L	Seitenpaneel LI	Panneau latéral gauche	Panel lateral izquierdo.
3	01.02.12602 Cofano inferiore	Base (metal)	Unteres gehäuse	Carter inférieur	Chapa inferior
4	01.03.05802 Pannello laterale DX	Side panel - R	Seitenpaneel RE	Panneau latéral droit	Panel lateral dcho.
5	74.90.008 Kit plastiche frontali	Plastic parts - spare kit	Kit kunststoffteile	Kit parties en plastique	Kit partes plásticas externas
6	74.90.009 Kit plastiche posteriore	Rear panel (plastic) - spare kit	Kit hintere kunststoffteile	Kit parties en plastique arrière	Kit partes plásticas posteriores
7	03.05.177 Pannello comandi FP337	Control panel FP337	Steuerpult FP337	Panneau commandes FP337	Panel mandos FP337
8	03.05.111 Targa posteriore	Rear nameplate	Hinterschild	Plaque arrière	Placa posterior
9	19.50.053 Innesto rapido acqua 1/8" blu	Quick connector H2O (blue) - 1/8"	Wasserschnellanschluss 1/8" blau	Raccord rapide eau 1/8" bleu	Conexión rápida agua 1/8" azul
10	19.50.054 Innesto rapido acqua 1/8" rosso	Quick connector H2O (red) - 1/8"	Wasserschnellanschluss 1/8" rot	Raccord rapide eau 1/8" rouge	Conexión rápida agua 1/8" rojo
11	24.01.026 Raccordo 1/4"-1/8"	Fitting 1/4"-1/8"	Anschluss 1/4"-1/8"	Raccord 1/4"-1/8"	Racor 1/4"-1/8"
12	07.23.009 Pompa idraulica rotativa	Peripheral electrical pump	Kreiselpumpe	Pompe hydraulique rotative	Bomba hidráulica rotativa
13	14.70.055 Ventilatore	Fan	Ventilator	Ventilateur	Ventilador
14	05.11.009 Trasformatore	Transformer	Transformator	Transformateur	Transformador
15	15.18.058 Kit scheda elettronica	P.c. board - spare kit	Kit elektronische karte	Kit platine	Kit tarjeta electrónica
16	20.04.151 Serbatoio	Tank	Tank	Réservoir	Depósito
17	24.01.162 Portagomma 1/4"	Hose holder 1/4"	Schlauchhalter 1/4"	Porte tuyau 1/4"	Boquilla manguera 1/4"
18	19.50.064 Portagomma 2.5mm	Hose holder 2.5mm	Schlauchhalter 2.5mm	Porte tuyau 2.5mm	Boquilla manguera 2.5mm
19	18.81.007 Scambiatore di calore	Heat exchanger	Wärmetauscher	Echangeur de chaleur	Intercambiador de calor
20	09.08.002 Pressostato	Pressure switch	Druckschalter	Pressostat	Pressostato
*	07.23.013 Tenuta meccanica pompa	Waterproof	Mechanische pumpendichtung	Garniture mécanique pompe	Cierre mecánico bomba
*	18.91.001 Liquido anticongelante (10kg)	Antifreezing liquid (10kg)	Frostschutzmittel (10kg)	Liquide antigel (10kg)	Liquido anticongelante (10kg)
*	21.04.002 Tubo pvc retinato 6x12	Braided pvc hose - 6x12	Pvc-gewebeschlauch 6x12	Tuyau pvc avec gaine de protection 6x12	Manguera pvc con malla 6x12
*	91.08.337 Manuale istruzioni "A"	"A" instruction manual	Bedienungsanweisungen "A"	Manuel d'instructions "A"	Manual instrucciones "A"
*	91.09.058 Manuale istruzioni "B"	"B" instruction manual	Bedienungsanweisungen "B"	Manuel d'instructions "B"	Manual instrucciones "B"

"A" = IT-GB-DE-FR-ES-NL-DK-FI-SE-NO-CR-PT

"B" = CZ-PL-RU-TR-RO-BG-SK

voestalpine

ONE STEP AHEAD.

voestalpine Böhler Welding
www.voestalpine.com/welding